

April 18, 1997

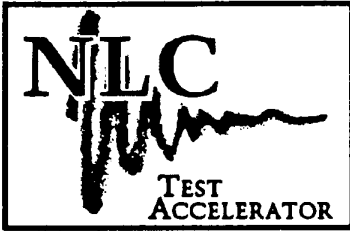

Subject: Calculating RF Profiles for Beam
Loading Compensation of Arbitrary
Current Profiles.

Authors: C. D. Nantista, C. Adolphsen

In the NLCTA, as in the NLC design, the energy variation along the multi-bunch beam pulse is controlled by preloading the structure with a ramped rf profile, which is followed by constant amplitude rf. In the NLCTA, the rf is shaped by modulating the phase of klystron pulses^[1] feeding a SLED-II pulse compressor^[2]. The duration of the required ramp is nominally the fill time minus the structure length divided by c . This is illustrated in Figure 1, which shows qualitatively the rf pulse shape and (with different shading) how it fills the structure at beam injection, at steady state, and at a point inbetween. The increasing gradient from the injected rf cancels the increasing retarding field due to beam loading build-up.

The shape of such a ramp, linear or nearly linear in field strength, has been previously calculated by Kathy Thompson^[3] for a constant gradient structure and by Juwen Wang^[4] for the detuned structure^[5]. For those calculations, a constant charge population along the bunch train was assumed. Experience with the NLCTA pulsed thermionic gun reveals a current profile which varies somewhat from a perfect square pulse, with a rise time of several nanoseconds. This note develops, from basic equations, a method for calculating the tailored rf profile necessary to compensate beam loading for an arbitrary (bunched) beam current pulse shape.

For the purpose of beam loading calculation, it is necessary to know certain characteristics of the accelerator structure, such as the shunt impedance, quality factor, and group velocity, or, alternatively, the loss parameter, attenuation parameter, and group velocity. These generally vary smoothly along the structure's length. Rather than as discrete parameters evaluated for each cell, we shall treat them as continuously varying functions of position. For the NLCTA structure, they were obtained by running the code MAFIA for fifteen representative cells and using a cubic spline interpolation.

The power flowing past any point in the accelerator structure is

$$P = wv_g.$$

The power flowing past any point in the accelerator structure is

$$P = wv_g,$$

and the loss parameter per unit length is given by

$$k_l = \frac{\omega}{4} \frac{r}{Q_0} = \frac{E_a^2}{4w}.$$

We can thus express the accelerating field by

$$E_a = 2\sqrt{k_l w} = 2\sqrt{\frac{k_l}{v_g}} P^{1/2}.$$

Since power is proportional to electric field squared, let's write

$$E_a = 2\sqrt{\frac{k_l}{v_g}} E_{rf}, \quad \text{with} \quad E_{rf}(t) \equiv \sqrt{P_{in}(t)}.$$

As it flows along the structure, power is attenuated by ohmic loss as

$$P(s) = P_{in} e^{-2\int_0^s \alpha(s') ds'}, \quad \text{where} \quad \alpha(s) = \frac{\omega}{2v_g(s)Q_0(s)}.$$

Let the beam enter the structure at time $t=0$. The rf should reach the end of the structure just as the beam does, at $t=L/c$. Any energy arriving sooner would be wasted, never seen by the beam. If we call the leading edge of the power pulse $P(0)$, then at time $t=0$, $P(T_f - L/c)$ is entering the structure, and the accelerating field along the structure is

$$\begin{aligned} E_a(s, t=0) &= 2\sqrt{\frac{k_l(s)}{v_g(s)}} \sqrt{P\left(T_f - \frac{L}{c} - \int_0^s \frac{ds'}{v_g(s')}\right)} e^{-2\int_0^s \alpha(s') ds'} \\ &= 2\sqrt{\frac{k_l(s)}{v_g(s)}} E_{rf}\left(T_f - \frac{L}{c} - \int_0^s \frac{ds'}{v_g(s')}\right) e^{-\int_0^s \alpha(s') ds'}. \end{aligned}$$

Now, an electron bunch entering the structure at time t reaches position s at time $t+s/c$, so the total acceleration it gets from the rf (neglecting beam loading) is given by

$$V_{rf}(t) = \int_0^L 2\sqrt{\frac{k_l(s)}{v_g(s)}} E_{rf}\left(T_f - \frac{L}{c} + t + \frac{s}{c} - \int_0^s \frac{ds'}{v_g(s')}\right) e^{-\int_0^s \alpha(s') ds'} ds.$$

Note that we assume the rf phase is constant and the beam is highly relativistic and on crest. A cosine factor could be added to make the problem more general. We also assume a tightly bunched beam. If the beam cannot be treated as a time

series of weighted delta functions, the square of the bunch form factor^[6] should multiply the loss parameter here and in what follows.

Defining the useful function

$$\tau_0(s) \equiv \int_0^s \left(\frac{1}{v_g(s')} - \frac{1}{c} \right) ds',$$

we can rewrite the above equation as

$$V_{rf}(t) = \int_0^L 2 \sqrt{\frac{k_l(s)}{v_g(s)}} E_{rf}(t + \tau_0(L) - \tau_0(s)) e^{-\int_0^s \alpha(s') ds'} ds.$$

The single-bunch beam loading is given by

$$V_{bl}^{sb}(t) = \int_0^L k_l(s) ds q(t) = \frac{I(t)}{f_b} \int_0^L k_l(s) ds = \frac{K_0}{f_b} I(t),$$

where f_b is the intra-pulse bunching frequency. This small contribution only affects energy variation when the current is not a square pulse. For practicality, we omit the effect of higher order mode loss parameters.

The multi-bunch beam loading is more complicated. Charge traversing the structure deposits locally an energy per unit length

$$w(s) = k_l(s) q^2,$$

inducing an accelerating field

$$E_a = 2\sqrt{k_l w} = 2k_l q.$$

As this energy travels along the structure, it is attenuated as $e^{-\int_s^t \alpha(s') ds'}$ and compressed as $v_g(\sigma)/v_g(s)$, where σ is the point of origin of the deposited energy and s its current position. Thus

$$\begin{aligned} E_a(s, \sigma) &= 2 \sqrt{k_l(s) k_l(\sigma) q^2 e^{-2 \int_\sigma^s \alpha(s') ds'} \frac{v_g(\sigma)}{v_g(s)}} \\ &= 2 \sqrt{k_l(s) k_l(\sigma)} \sqrt{\frac{v_g(\sigma)}{v_g(s)}} e^{-\int_\sigma^s \alpha(s') ds'} q. \end{aligned}$$

Now, when an element of charge $I(t) dt$ arrives at position s at time $t + s/c$, it "sees" the accumulation of fields generated by preceding charge elements ($t' < t$) at upstream positions $\sigma(s, t - t')$ and times $t' + \sigma(s, t - t')/c$, modified by the appropriate factors. Simultaneous arrival at s requires

$$t + \frac{s}{c} - \left(t' + \frac{\sigma(s, t - t')}{c} \right) = \int_{\sigma(s, t - t')}^s \frac{ds'}{v_g(s')}.$$

The position $\sigma(s, t - t')$ is thus determined from

$$\tau = \int_{\sigma(s, \tau)}^s \left(\frac{1}{v_g(s')} - \frac{1}{c} \right) ds',$$

with $\tau = t - t'$. The (non-self) multi-bunch beam loading voltage is given by the double integral

$$V_{bl}^{mb}(t) = 2 \int_0^L \int_{\max[0, t - \tau_0(s)]}^t I(t') \sqrt{k_l(s) k_l(\sigma(s, t - t'))} \sqrt{\frac{v_g(\sigma(s, t - t'))}{v_g(s)}} e^{-\int_{\sigma(s, t - t')}^s \alpha(s') ds'} dt' ds.$$

The first choice for the lower limit on the time integration is determined by the assumption that $I(t < 0) = 0$, and the second by the fact that no energy comes from position $\sigma < 0$. Changing variables to $\tau = t - t'$, we can recast the above equation as

$$V_{bl}^{mb}(t) = 2 \int_0^L \int_0^{\min[t, \tau_0(s)]} I(t - \tau) \sqrt{k_l(s) k_l(\sigma(s, \tau))} \sqrt{\frac{v_g(\sigma(s, \tau))}{v_g(s)}} e^{-\int_{\sigma(s, \tau)}^s \alpha(s') ds'} d\tau ds.$$

(The limits of integration may be made more explicit by the expansion

$$\int_0^L \int_0^{\min[t, \tau_0(s)]} \rightarrow \int_0^{s_0(t)} \int_0^{\tau_0(s)} + \int_{s_0(t)}^L \int_0^t, \text{ where } \tau_0(s_0(t)) = t.)$$

The lower limit in the τ integration above should be an exclusive limit, so that the charge at time t ($\tau = 0$) does not contribute. Combining with the single-bunch beam loading, then, gives the total beam loading voltage loss

$$V_{bl} = V_{bl}^{sb} + V_{bl}^{mb}.$$

The total voltage gain in traversing the energized structure (on crest) is

$$V_{tot} = V_{rf} - V_{bl}.$$

Let V_{rf}^{\max} be the rf voltage gain with the structure filled with the maximum input power, V_{bl}^{\max} be the maximum (generally steady state) beam loading, and $V_{tot}^{s.s.}$ be their difference. To minimize energy variation along a bunch train with a given current profile, we need to fix the total gain at this constant value. That is, we require

$$V_{tot}(t) = V_{rf}(t) - V_{bl}(t) = V_{tot}^{s.s.}, \text{ or}$$

$$V_{rf}(t) = V_{tot}^{s.s.} + V_{bl}(t).$$

If we recast our integral equation for $V_{rf}(t)$ as a matrix equation,

$$\bar{\mathbf{V}}_{rf} = \mathbf{M}\bar{\mathbf{E}}_{rf} = \bar{\mathbf{V}}_{bl} + V_{\text{tot}}^{s.s.},$$

we can invert the matrix to solve for the desired rf amplitude profile,

$$\bar{\mathbf{E}}_{rf} = \mathbf{M}^{-1}(\bar{\mathbf{V}}_{bl} + V_{\text{tot}}^{s.s.}).$$

To obtain a matrix equation for $V_{rf}(t)$, we proceed as follows. Begin with

$$V_{rf}(t) = 2 \int_0^L \sqrt{\frac{k_l(s)}{v_g(s)}} E_{rf} \left(T_f - \frac{L}{c} + t - \tau_0(s) \right) e^{-\int_0^s \alpha(s') ds'} ds.$$

Define

$$A(s) = 2 \sqrt{\frac{k_l(s)}{v_g(s)}} e^{-\int_0^s \alpha(s') ds'},$$

and rewrite the equation as a double integral with a delta function.

$$V_{rf}(t) = \int_0^L \int_{-\infty}^{\infty} A(s) E_{rf}(t') \delta \left(t' - T_f + \frac{L}{c} - t + \tau_0(s) \right) dt' ds.$$

Reverse the order of integration, using the definition of $\tau_0(s)$ and recasting the delta function in terms of s .

$$V_{rf}(t) = -c \int_t^{t+T_f-L/c} E_{rf}(t') \int_0^L A(s) \delta \left(s - c \int_0^s \frac{ds'}{v_g(s')} - c \left[t' - T_f + \frac{L}{c} - t \right] \right) ds dt'.$$

The limits on t' follow from the limits on s . Now, we must make the following change of variables:

$$x \equiv -c\tau_0(s) = s - c \int_0^s \frac{ds'}{v_g(s')},$$

$$\frac{dx}{ds} = 1 - \frac{c}{v_g(s)} \rightarrow ds = \frac{dx}{1 - \frac{c}{v_g(s(x))}},$$

and obtain

$$\begin{aligned}
V_{rf}(t) &= -c \int_t^{t+T_f-L/c} E_{rf}(t') \int_0^{L-cT_f} \frac{A(s(x))}{1 - \frac{c}{v_g(s(x))}} \delta\left(x - c\left[t' - T_f + \frac{L}{c} - t\right]\right) dx dt' \\
&= \int_t^{t+T_f-L/c} \frac{A\left(s\left(L - cT_f - c(t-t')\right)\right)}{\frac{1}{v_g\left(s\left(L - cT_f - c(t-t')\right)\right)} - \frac{1}{c}} E_{rf}(t') dt'.
\end{aligned}$$

Finally, we have an equation that can be written, for a finite time step, preferably the bunch spacing, in matrix form. Let

$$x(t, t') = L - cT_f - c(t - t'),$$

$$M(t, t') = \frac{A(s(x(t, t')))}{\frac{1}{v_g(s(x(t, t')))} - \frac{1}{c}},$$

$$t_i = i \Delta t, \quad i = 1, 2, \dots, N$$

$$\mathbf{M}_{ij} \equiv \begin{cases} M(t_i, t_j) \Delta t, & t_i \leq t_j < t_i + T_f - L/c \\ 0, & \text{otherwise,} \end{cases}$$

$$\mathbf{E}_{rfj} \equiv E_{rf}(t_j), \quad \text{and} \quad \mathbf{V}_{rfi} \equiv V_{rf}(t_i).$$

Then

$$\mathbf{V}_{rfi} = \sum_j \mathbf{M}_{ij} \mathbf{E}_{rfj}, \quad \text{or} \quad \bar{\mathbf{V}}_{rf} = \mathbf{M} \bar{\mathbf{E}}_{rf}.$$

Note that $M(t_i, t_j)$ is a function of $t_i - t_j$, so that, in constructing the matrix \mathbf{M} , it is only necessary to calculate $(T_f - L/c)/\Delta t$ distinct elements. These fill the beginning of the first row and are displaced by one element in each successive row, as shown in Figure 2, until the last of the rf pulse reaches the end of the structure.

To avoid wasteful computation, it is also possible to compute and save for the beam loading calculation a matrix which depends only on the structure. Render the position and time integrations as discrete sums so that $s_i = i \Delta s$ and $\tau_j = j \Delta t$, with $i = 1, 2, \dots, L/\Delta s$ and $j = 1, 2, \dots, (T_f - L/c)/\Delta t$. Then define

$$\mathbf{A}_{ij} = \begin{cases} 2\sqrt{k_l(s_i)k_l(\sigma(s_i, \tau_j))} \sqrt{\frac{v_g(\sigma(s_i, \tau_j))}{v_g(s_i)}} e^{-\int_{\sigma(s_i, \tau_j)}^{s_i} \alpha(s') ds'} \Delta t \Delta s, & \tau_j \leq \tau_0(s_i) \\ 0, & \tau_j > \tau_0(s_i). \end{cases}$$

Now, for any given current profile, the double integral for $V_{bl}^{mb}(t_k)$, where $t_k = k \Delta t$, is evaluated by first multiplying by the matrix \mathbf{A} a vector containing the discretized current values in reverse order from t_{k-1} to 0, followed by zeros, and then summing the elements of the resulting vector. The matrix multiplication effects the τ integration and the summing the s integration. Figure 3 illustrates the population of \mathbf{A} and the current vector $\bar{\mathbf{I}}_k$, showing the two possible limits in the τ integration. For efficiency, only the non-zero part of each $\bar{\mathbf{I}}_k$ vector is actually multiplied by the appropriate subarray of \mathbf{A} .

$$V_{bl}^{mb}(t_k) = \sum_i \sum_{j=1}^k \mathbf{A}_{ij} \mathbf{I}_{k_j} = \sum_i \sum_{j=1}^k \mathbf{A}_{ij} I(t_{k-j}).$$

As an example, we consider a beam pulse with a 10ns, exponential rise time (10%-90%) and a peak current of one ampere. For the 1.8m detuned structure, the beamloading follows the solid curve in Figure 4a. The desired rf profile for a steady state input power of 100MW is shown by the solid curve in Figure 4b. If we require the steady state power to be the maximum achievable power, we cannot exactly compensate the first couple of nanoseconds of the beam here, but this represents very little current, since it is on the rising edge. In both plots, a dashed curve indicates the solution for a square current profile.

We hope that this brief note will prove useful in refining the compensation of transient beam loading effects for long bunch trains in traveling-wave accelerators. It should be pointed out that one physical effect not accounted for in this theoretical treatment is rf dispersion in the disk-loaded structure.

Acknowledgement: Thanks to Kwok Ko and Cho Ng for help in running MAFIA.

References:

- [1] C. Adolphsen, *et al.* "Beam Loading Compensation in the NLCTA", presented at the 1997 Particle Accelerator Conference, Vancouver, BC, Canada, May 11-16 1997, SLAC-PUB-?.
- [2] Christopher Dennis Nantista, *Radio Frequency Pulse Compression for Linear Accelerators*, pp. 167-171, SLAC-Report-95-455, January 1995.
- [3] SLAC, *Next Linear Collider Test Accelerator Conceptual Design Report*, pp. 32-33, SLAC-Report-411, August 1993.
- [4] The NLC Design Group, *Zeroth-Order Design Report for the Next Linear Collider*, pp. 472-474, LBNL-PUB-5424 / SLAC Report 474 / UCRL-ID-124161, May 1996.
- [5] *ibid.*, pp. 466-472.
- [6] Perry B. Wilson, *High Energy Electron Linacs: Applications to Storage Ring RF Systems and Linear Colliders*, pp.9-10, SLAC-PUB-2884, February 1982.

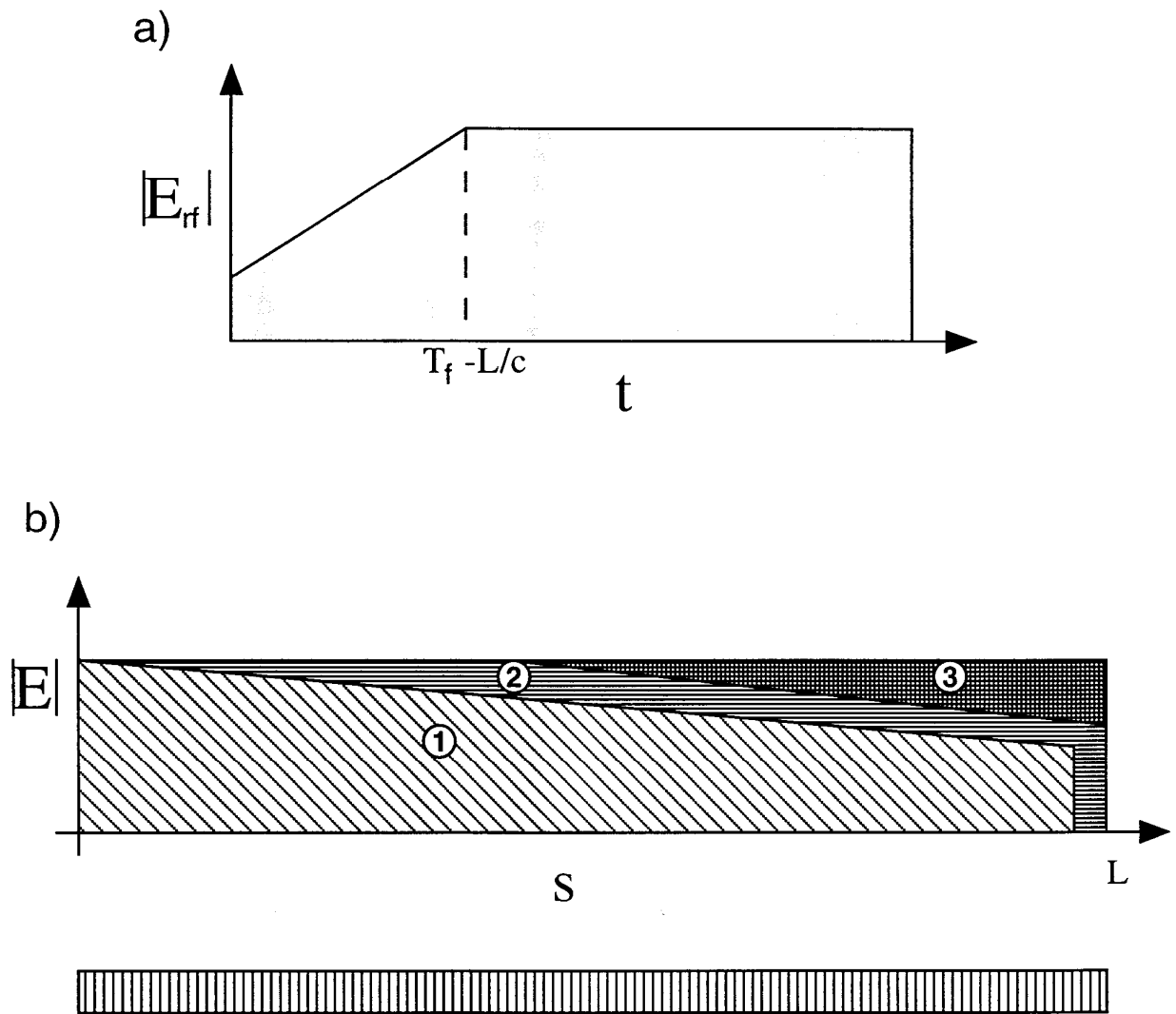

Figure 1. a) Ramped rf waveform input to the accelerator structure. b) Input rf field profile along the structure at (1) beam injection, (2) an intermediate point, and (3) steady state.

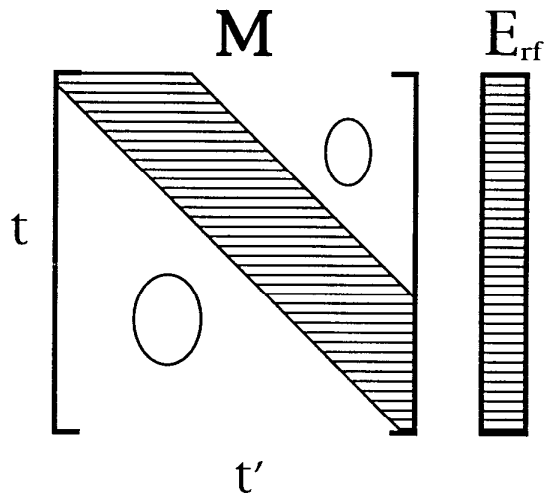

Figure 2. RF acceleration matrix.

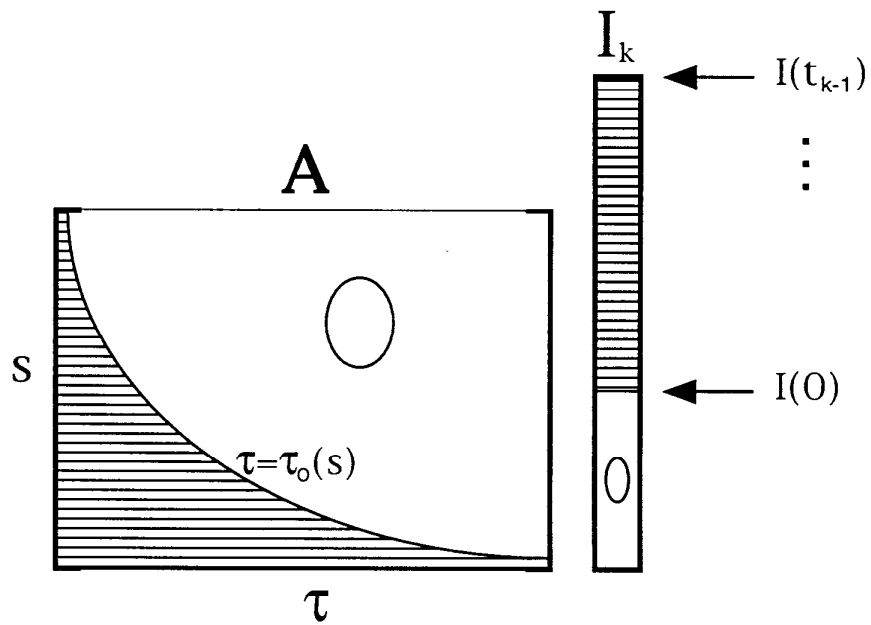
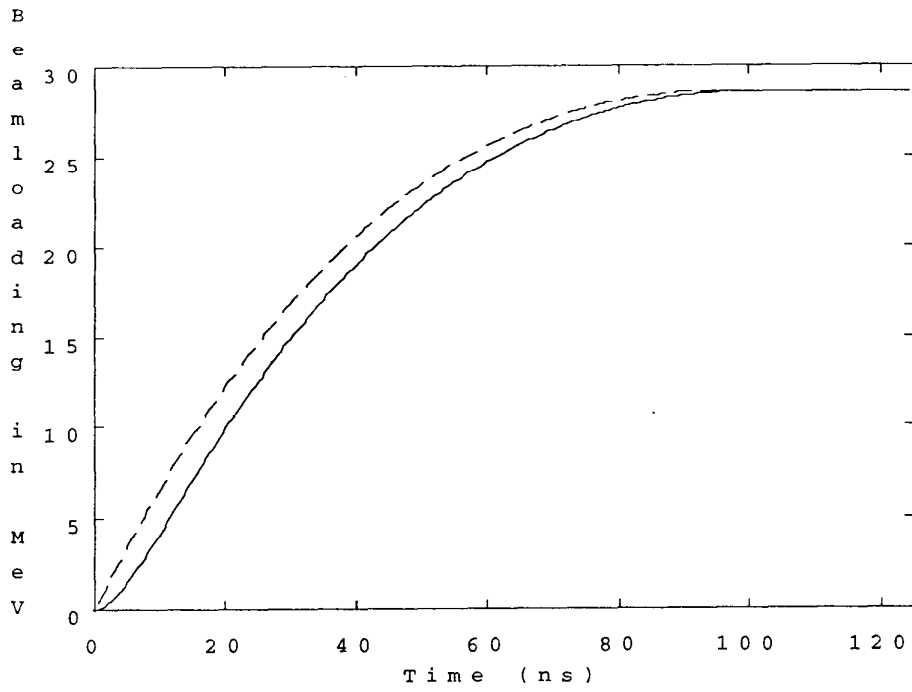
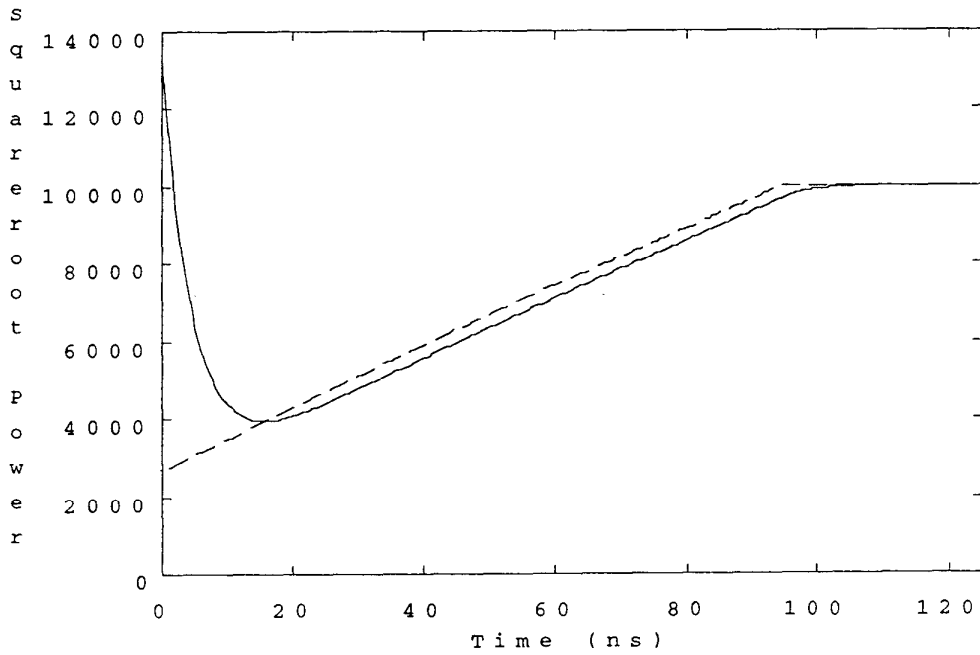

Figure 3. Beam loading matrix.



a)



b)

Figure 4. a) Beam loading vs. injection time and b) compensating rf profile for square (dashed) and 10ns rise time (solid), 1A pulses in the NLCTA detuned structure