



To: Hesham Khater,
NLCTA Radiation Physicist

June 20, 2002

From: Keith Jobe
NLCTA Safety Officer

Subject: Operation of the 8-Pack Klystron Power Supply

CC: Nelson, Rokni, Kase, Bong, Kroutil, Cisneros, Larsen,
Humphrey, Burke, Atkinson, Schultz, Cassel, Saleski, Ross

Hesham,

Please help me in obtaining the needed permissions to operate the klystrons for the 8-Pack project at the NLCTA in End Station B in the manner described below. Since the klystrons will not be connected to the accelerator for this phase of the operation, we believe that this experimental program is not part of the NLCTA BAS and will require another form of authorization. Please let me know what you would like me to do.

Patrick Bong's general proposal on the interlocking of the high voltage power supply seems reasonable and complete, and corresponds to the radiation protection strategy previously discussed with the Radiation Physics group. I am asking him to construct and install it, and to connect it to the existing NLCTA PPS system. (Some fraction of the existing NLCTA PPS system will need to be recertified when the chassis is connected.)

The gory details of the PPS interlock aspect of the proposal can be found at the end of this document.

The project description and the radiological controls for this phase of the 8-Pack operation are summarized below:

- Four 50 MW XL-4 klystrons will be installed in the modulator by late July 2002. Initially, they will be used as power loads for the modulator and only incidental amounts of rf power will be generated. The only radiation exposure expected from this initial phase of operation will be emissions from the klystron collector. These are the SLAC standard X-band klystrons which have been shielded and surveyed by the klystron department. No radiological surprises are expected at this point.

Note that we initially planned to use the 75 MW XP-3 klystrons which are poorly shielded. While we intend to use a more modern klystron soon (perhaps even the XP-3), initially we will be using the XL-4 klystrons. While this is a minor setback for our program, it does remove a significant uncertainty regarding the klystron's intrinsic radiation from beam interception and from the collector.

- Shortly following the initial installation of the modulator and the klystrons, the klystrons will be attached to rf drive sources (TWTA amplifiers), and in several steps connected to larger systems of high power rf distribution and combining hardware (but explicitly not to any accelerating structure and not to any device inside the Accelerator Enclosure). As we have discussed, we anticipate the

possibility of radiation emission from the rf hardware at this point. Administrative programs of radiation surveying and shielding will be developed as we develop a better understanding of the radiological-emissions of the system.

- The high power modulator power supply will be wired into the existing NLCTA PPS system in the following novel manner; the output signal from the BSOIC detectors ("Sum OK") will be an interlock for the 8-Pack klystron power supply system. The power supply will trip off when any NLCTA BSOIC trips for any reason and will stay off until an operator has determined the source of the trip and reset the detector (see the [BSOIC Trip Alarm Response Procedure](#)¹ 02-05-05). While this interlock should be complete prior to the first phase of the program described above (operation without rf), it is necessary and must exist in a certified form and operate correctly before high power rf is generated.
- There are three BSOIC radiation detectors in the immediate vicinity of the klystrons and the high power rf combining hardware. Two are located on the floor of the End Station close to the klystrons and the start of the rf transport and combing systems, and one is located on the roof near the final rf transport system. They are required by the NLCTA BAS and are set to trip at 10 mR/hr.
- At a later phase, the output power from the 8-Pack will be used to power rf devices in the Accelerator Enclosure (the "Tunnel"). It is understood that at that time the operation will need to be included in the NLCTA Directives (02-02-01) and will require a modification of the BAS.
- The interlocks for the modulator power supply follow the usual convention for redundant control of the electrical hazard sources at SLAC². When the 8-Pack is more fully developed and is used to power devices inside the Tunnel, this same control cable will be transferred to the NLCTA Stopper Control Chassis and operation of the 8-Pack will require the tunnel to be in No Access with Search Complete and Stoppers Enabled.

¹ http://www-project.slac.stanford.edu/lc/local/Projects/NLCTA/Operations%20Documents/OP%20DOC.pdf/020505%20BSOIC_Trip.pdf

² The NLCTA Stopper Control standard as it currently exists deviates slightly from the Electrical Hazard Interlock. The intention of the PPS group is to modify the existing NLCTA system to correspond to the prevailing SLAC standard.

Keith,

Per our conversation, Monday June 17, I have decided to make changes to the NLCTA PPS as follows;

I plan to make a modification to the NLCTA Stopper Control Chassis (292-060) to make it compatible with the standard pin-out for PPS controlled power supplies. This will allow the 8-pack designers to follow the established interface rules for PPS controlled power supplies and eliminate problems with the future cutover when the 8-pack becomes a radiation hazard in the NLCTA housing. The general idea is to use the standard Burndy 8-pin connector at the 8-pack power supply and use the existing 12-pin connector at the stopper control chassis to support existing equipment. Currently the stopper control chassis supports the standard 8-pin pin-out plus two extra pins per modulator. The gun input to the chassis is the standard 8-pin configuration. The extra two pins report "Stopper On" status. The "Stopper On" status signal was an implementation to evaluate possible future PPS designs and has since been abandoned.

My proposal is to modify the "Stopper On" status to report ON when
(NOT "Stopper Off" chain A) AND (NOT "Stopper Off" chain B),
since the "Stopper Not Off" status is
(NOT "Stopper Off" chain A) OR (NOT "Stopper Off" chain B)

The output of the NLCTA 8-Pack Interface Chassis will have a 12-pin Burndy connector to make the interface plug-compatible with the stopper chassis. I have attached the relevant drawings, note that the stopper control chassis drawing has not been updated to reflect the future changes.

Thanks,
Patrick Bong

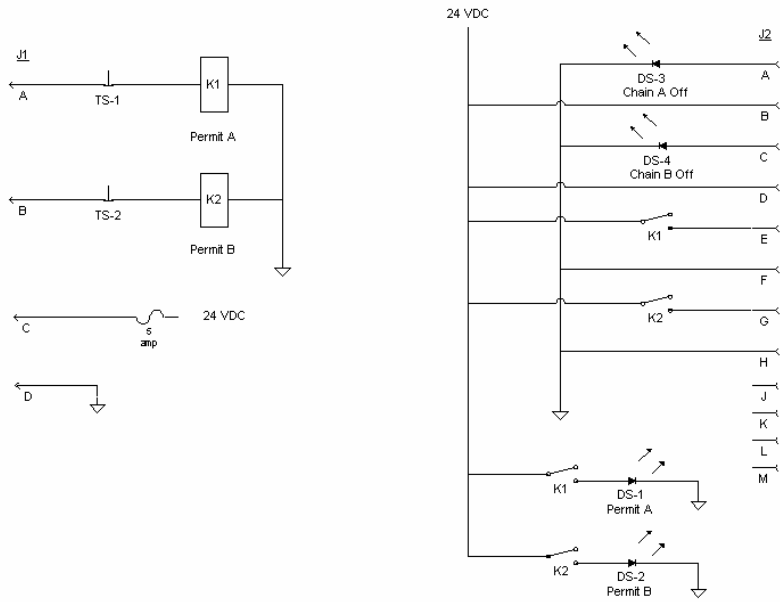

Engineer: P. Bong 6-18-2002

NLC TEST ACCELERATOR
 PPS STOPPER CONTROL
 8-PACK POWER SUPPLY INTERFACE
 WD-292-061-00-C0

