

Fiducials for QFC Std. Vac. Chamber

QFC019

Date:

1/11/02

Chamber:

QFC019

Operator(s):

F. Gaudreault
L. Griffin

Notes:

Traveler Step #1200: 11/8/01; #1280: 11/27/01. Step #1380 and #1465 below.

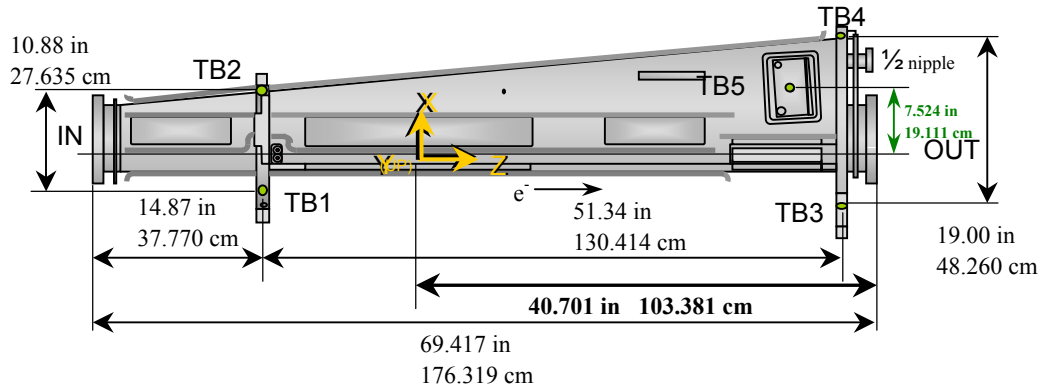

Fiducial Coordinates for QFC Standard Vacuum Chamber: (inches)

Fiducial	Z	X	Y
TB1	-13.790	-3.520	4.398
TB2	-13.841	7.213	4.371
TB3	37.462	-5.465	4.407
TB4	37.524	13.232	2.978
TB5	33.440	7.569	2.080
TB6			
TB7			

TB5 _x Absorber Check	
Measured	7.569
Nominal	7.524
Difference	0.045

STATUS: **OK**
< 0.100 in

Source: **US Step**

Description:
Fid. vals based on internal chamber datum. Source="US Step" indicates final data unless rechecked.

Flange Positions: (inches)

Flange	Z	X	Y	Source
IN	-28.618	1.834	0.012	US
OUT	40.701	1.850	0.003	DS
NIP	N/A	10.520	-0.004	DS

Source: **US Step**

Description:
Flange values based on scans of flange surfaces and referenced to internal chamber datum.

Fiducialization Step: (Traveler Step # 1380: 1/9/02)

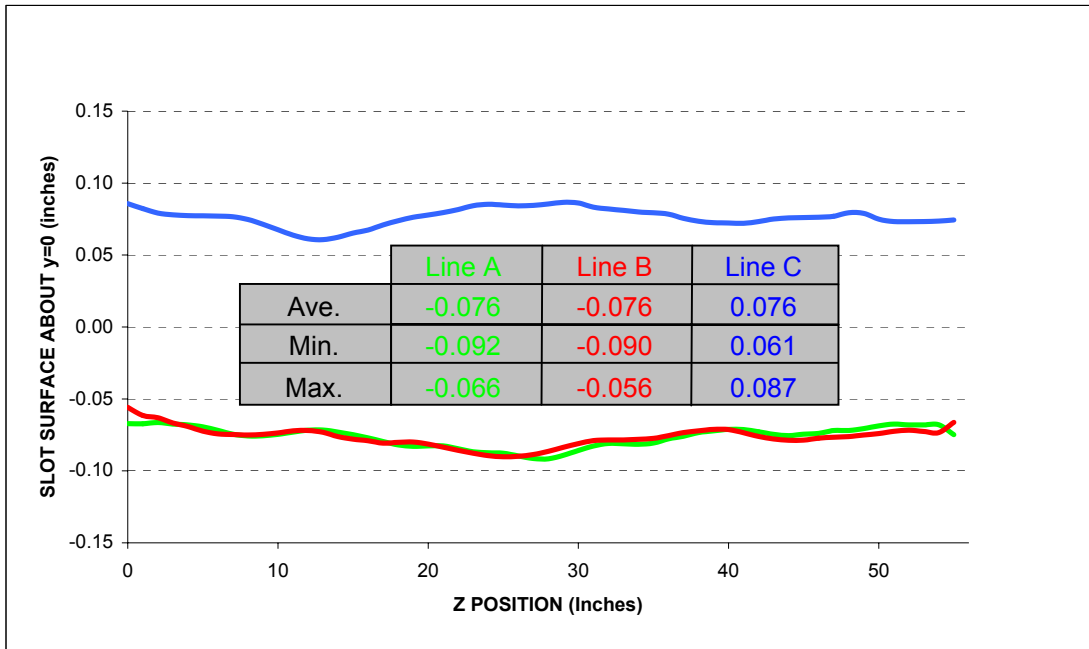

QFC019

Step 1: Fiducial and Flange Coordinates for QFC Std. Vac. Chamber

Fiducial	Z	X	Y	Downstream Flanges	
TB1	-13.790	-3.520	4.398	OUT	NIP
TB2	-13.841	7.213	4.371	Z	41.451 N/A in
TB3	37.462	-5.465	4.407	X	1.842 10.520 in
TB4	37.524	13.232	2.978	Y	-0.004 -0.004 in
TB5	33.440	7.569	2.080		
TB6					
TB7					
	inches	inches	inches	Nominals:	Xout: 1.836 Yout: 0.000

Description:
Fiducial values based on internal chamber datum. Flange OUT X and Y values checked ± 0.020 in.

Status

Step 2: Downstream Flange Check

Flange	Yaw	Pitch	Diameter		Nominal Diameter
			Meas.	Actual	
OUT	-11.79	2.22	11.469	9.969	9.970 OK
NIP	N/A	N/A	4.231	2.731	2.730 OK ??
	mrad	mrad	inches		± 0.015 in

Description:
Yaw -6 to -13 mrad. Pitch ± 3 mrad. Diameter difference ± 0.015 in

Step 1: Change in Fiducial Values Check

Fiducial	Delta Z	Delta X	Delta Y
TB1	0.000	0.000	-0.005
TB2	0.001	0.000	0.005
TB3	-0.001	0.001	0.003
TB4	0.001	0.001	-0.002
TB5	0.000	-0.001	-0.001
TB6			
TB7			

inches inches inches

OK

OK

OK

OK

OK

±0.006 in

Description:
Difference between current and previous fiducial values.

Global: **OK**

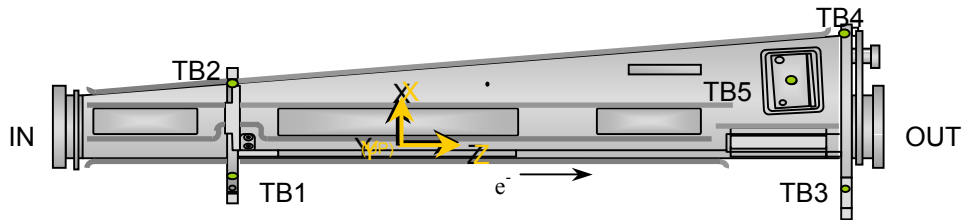

Step 2: Change in Downstream Flange Check

Flange	X	Y	Diameter
OUT			
New:	1.850	0.003	11.472 in
Delta:	0.008	0.007	0.003 in

Diameter:

UPDATE

X and Y: ±0.006 in

Diameter: ±0.015 in

Description:
Difference between current and previous fiducial values and diameter. If the current diameter is acceptable, only then will the corresponding X and Y vals be updated if either exceed the tolerance.

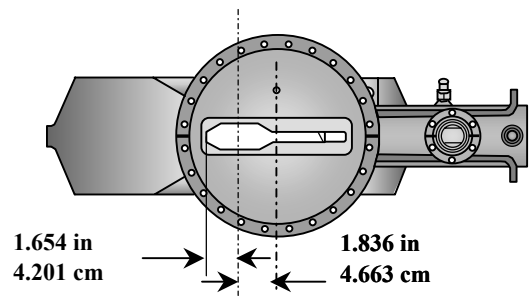

Final "Upstream Flange" Step (#1465 continued):

QFC019
Status

Step 3: Upstream Flange Values					
Flange IN		Flange IN			
-29.368	Z	6.39	-2.78	mrad	
1.834	X	Yaw	Pitch		
0.012	Y				
inches		Meas.	Actual	Nominal Diameter	
Diameter		11.469	9.969	9.970	OK
		in		±0.015 in	
Description:					
Location and orientation of Flange IN (upstream) plus its measured diameter.					
Flange IN X and Y values are also checked ±0.020 in. Yaw 5 to 9 mrad. Pitch ±3 mrad.					

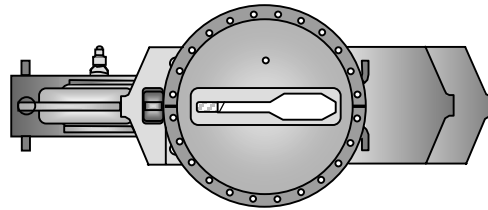

QFC019
Status

Step 4: QFC Chamber Length					
Length with SMR		Length		Nominal Length	
70.819	inches	69.319	inches	69.417	OK
Description:					
Length should be between nominal value and nominal value - 0.125 in.					

