

**Fiducials for BM1 Std. Vac. Chamber**

**BM1014**

Date:

4/5/02

Chamber:

BM1014

Operator(s):

F. Gaudreault  
L. Griffin

Notes:

First chamber done. US flange not measured.

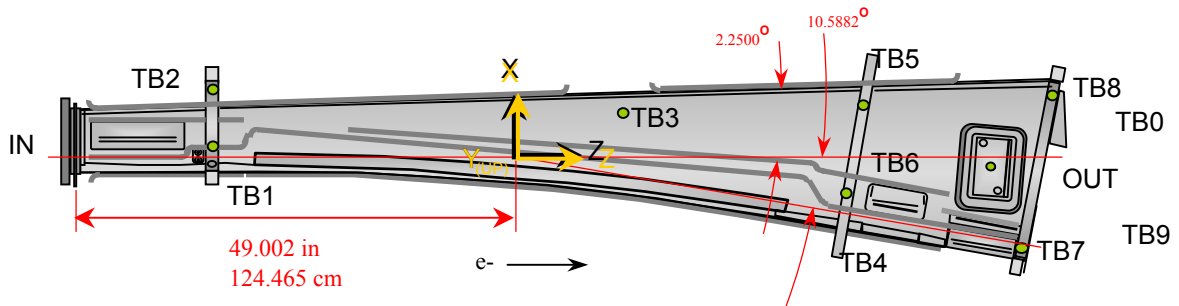

**Fiducial Coordinates for BM1 Standard Vacuum Chamber: (inches)**

Fiducial	Z	X	Y
TB1	-34.830	1.437	4.405
TB2	-34.874	8.325	4.407
TB3	10.974	4.162	2.367
TB4	34.547	-4.945	4.374
TB5	36.562	6.226	4.376
TB6	52.494	-1.920	2.320
TB7	55.676	-11.199	3.092
TB8	59.397	8.948	3.075
TB9 (V4)	74.649	-20.300	4.410
TB0 (V4)	77.000	-7.935	4.396
	inches	inches	inches

Nominal Deltas For H3 Absorber (TB6)		
Z	X	Y
52.499	-1.923	2.320
52.493	-1.891	2.242
<b>0.006</b>	<b>-0.032</b>	<b>0.078</b>

Source **V4 Step**

**Description:**

Fid. vals based on internal chamber datum. Source="V4 Step" indicates final data.

**Fiducialization Step: (Traveler Step # 1380)**

Slot Calibration	
Ideal	0.511
Meas.	0.126
Delta	-0.385

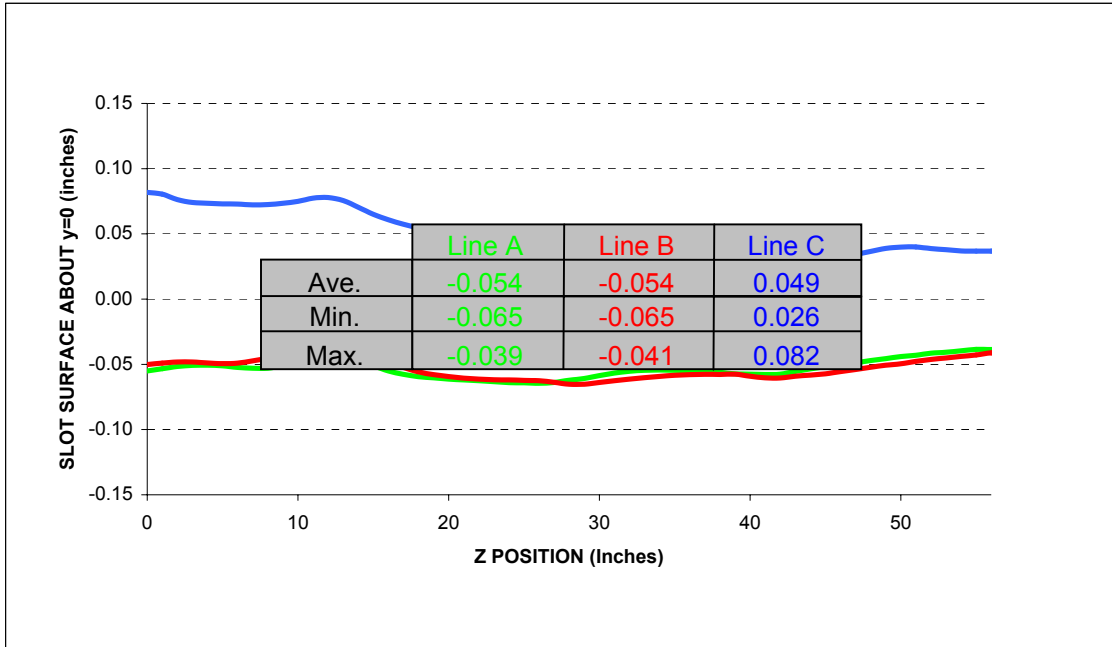

BM1014

**Step 1: Fiducial Coordinates for BM1 Std. Vac. Chamber**

Fiducial	Z	X	Y
TB1	-34.830	1.433	4.404
TB2	-34.892	8.319	4.408
TB3	10.972	4.176	2.367
TB4	34.544	-4.938	4.373
TB5	36.570	6.230	4.375
TB6	52.499	-1.923	2.320
TB7	55.677	-11.204	3.093
TB8	59.406	8.940	3.075
	inches	inches	inches

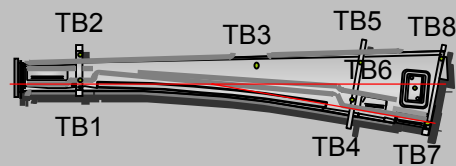

**Description:**

Fiducial values based on internal chamber datum.

End Surface Attitudes for BM1 Std. Vac. Chamber

Upstream Face		
	yaw	pitch
Measured	1.8	-6.4
Nominal	0.0	0.0
Difference	1.8	-6.4
	mrad	mrad

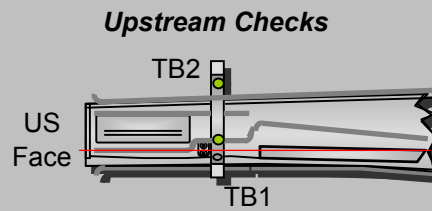

Downstream Port		
	yaw	pitch
Measured	24.3	-4.5
Nominal	25.3	0.0
Difference	-1.0	-4.5

**Downstream Checks**

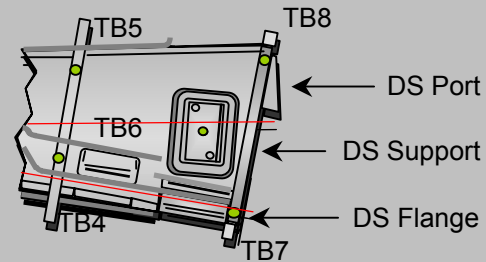

Downstream Support		
	yaw	pitch
Measured	-185.5	-4.1
Nominal	-184.8	0.0
Difference	-0.7	-4.1

Downstream Flange		
	yaw	pitch
Measured	-190.9	-2.3
Nominal	-184.8	0.0
Difference	-6.1	-2.3
	mrad	mrad

**Description:**

Orientation of the upstream and downstream surfaces compared to nominal values. Tol +/- 3 mrad

Datum Verification

DS Support	
	x
Measured	-11.901
Nominal	-11.912
Diff.	0.011
	inches

DS Flange	
	x
Measured	-11.944
Nominal	-11.958
Diff.	0.014
	inches

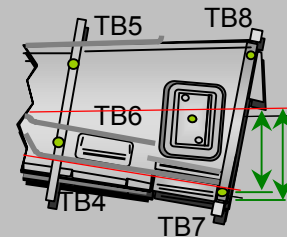

**Description:**

The x-distance from the center-line to the projection of the measured DS inside curve point on either of the DS surfaces. Tolerance values +/- 0.020 in.

<u>BM1 Chamber Lengths</u>			Nominal Length
Tangent Line:	Length 58.574 inches	without SMR	58.558 <span style="background-color: green; color: white; padding: 2px;">OK</span>
Orbit Line:	Length 57.512 inches	without SMR	57.569 <span style="background-color: green; color: white; padding: 2px;">OK</span>
<p><b>Description:</b> Both lengths are to the faces of the weld flanges. Length tolerance +/- 0.125 in.</p>			

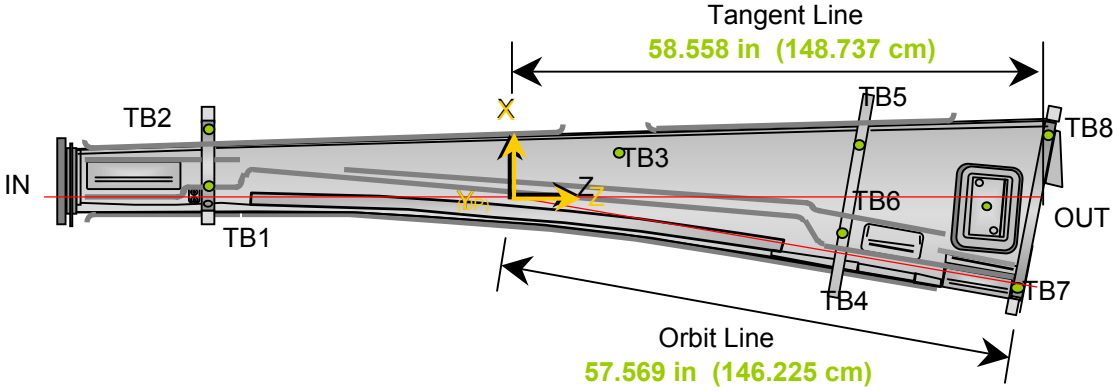

**V4 Step A: Survey and Check of BM1 Standard Vacuum Chamber Fiducials Before Attaching V4 and the Exit Port:**

**Step A-1: Remeasurement of Fiducial Coordinates for BM1 Std. Vac. Chamber**

Fiducial	Z	X	Y	del Z	del X	del Y
TB1	-34.833	1.437	4.401	-0.003	0.003	-0.003
TB2	-34.877	8.324	4.408	0.015	0.005	0.000
TB3	10.973	4.163	2.370	0.001	-0.013	0.003
TB4	34.547	-4.943	4.377	0.003	-0.006	0.004
TB5	36.564	6.226	4.378	-0.006	-0.004	0.003
TB6	52.496	-1.921	2.319	-0.003	0.003	-0.001
TB7	55.677	-11.200	3.090	0.000	0.004	-0.003
TB8	59.398	8.947	3.072	-0.008	0.008	-0.003

inches          inches          inches

**DS Port Level Check**

Level Status: OK

OK ?  (YES or NO)

**US Flange Roll Check**

Roll Status: OK

OK ?  (YES or NO)

Compared to Step 1 Fiducial Coords.

**Description:**  
Fid. vals based on internal chamber datum.

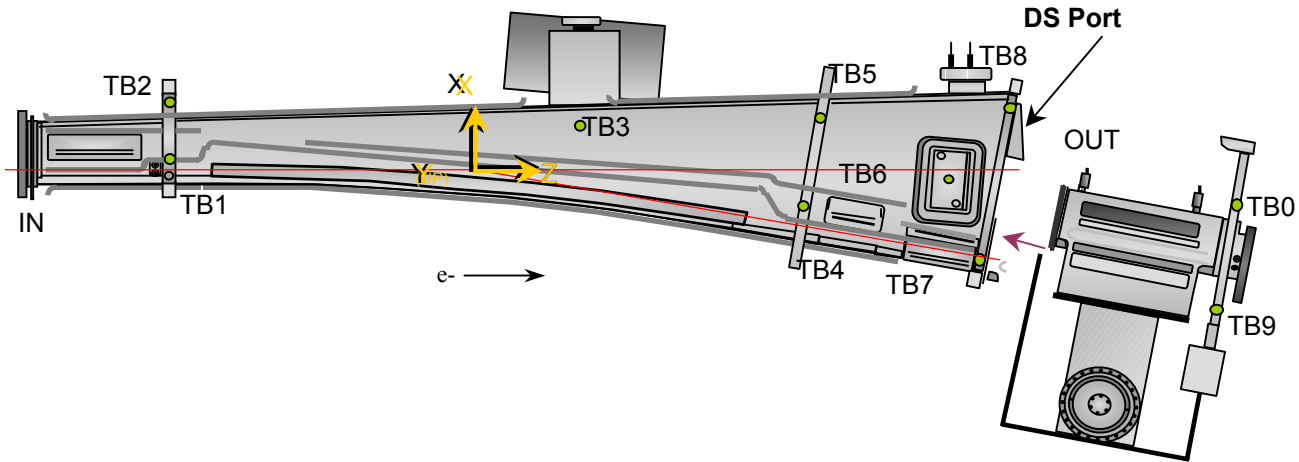

**V4 Step A: Check of US Flange Prior to V4 Installation**

**Step A-2: Pre-Installation Check of UpStream Flange Postion**

**Metrology Dept:**  
 This was the first chamber fiducialized. This step was not part of the procdure at that time. The Roll was taken out of the using a Sight Level.

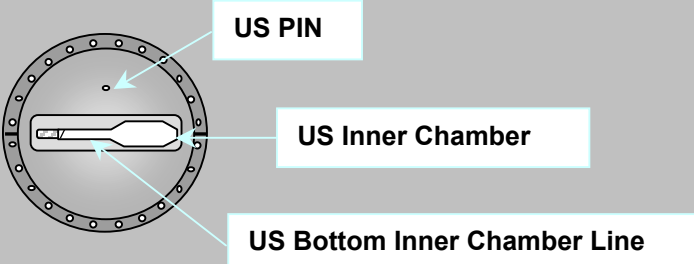

US PIN	Z	X	Y
Measured			
Nominal	-51.000	1.836	2.282
Difference (inches)	-----	-----	-----

US Inner Chamber	Z	X	Y
Measured			
Nominal	-51.000	-1.404	0.000
Difference (inches)	-----	-----	-----

US Bottom Inner Chamber Line	ROLL	(FINAL)
Measured		
Nominal	0.000	
Difference (mrads)	-----	

Roll Status  
**PENDING**

**Description:**  
 Measured vs. nominal values for US flange expressed in the PART coordinate system.  
 Fiducial values are updated (using those from Step A-1) if ROLL delta is not within 1mrad.

**V4 Fiducialization Step: Survey of Fiducial Coordinates for BM1 Standard Vacuum Chamber with V4 and the Exit Port Attached:**

**Step Fid-1: Position of Added Tooling Balls TB9 and TB0**

Fiducial	Z	X	Y
TB9 (V4)	74.756	-20.317	4.410
TB0 (V4)	77.105	-7.954	4.396
	inches	inches	inches

**Description:**  
 Fid. vals after V4 and exit port attached.

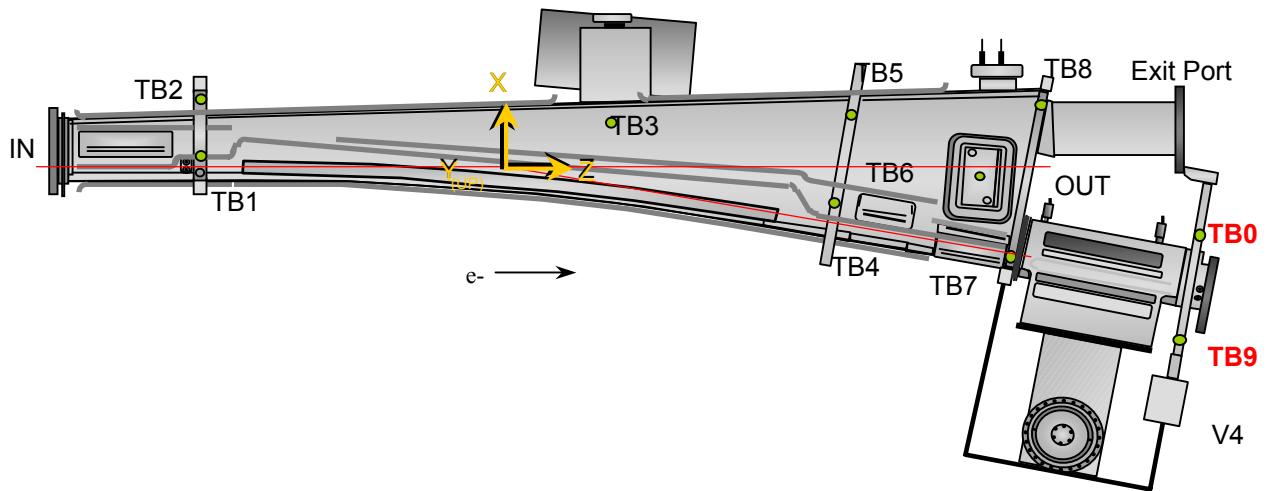

**V4 Fiducialization Step: V4 Flange**

**Step Fid-2: Set Position of V4 Flange Position**

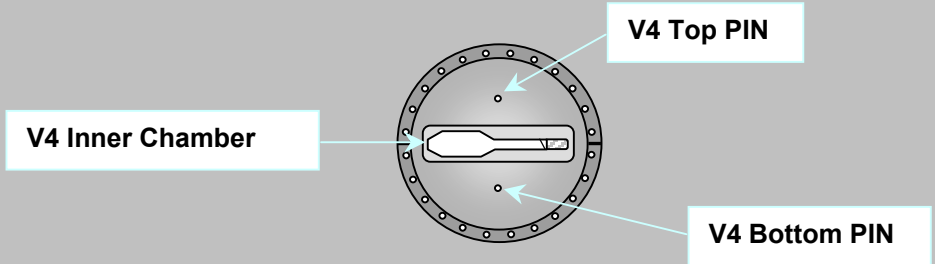

V4 Top PIN	Z	X	Y
Measured	81.110	-0.004	2.287
Nominal	80.000	0.000	2.282
Difference (inches)	1.110	-0.004	0.005

V4 Bottom PIN	Z	X	Y
Measured	81.087	-0.003	-2.280
Nominal	80.000	0.000	-2.282
Difference (inches)	1.087	-0.003	0.002

V4 Inner Chamber	Z	X	Y
Measured	80.069	-1.406	0.014
Nominal	80.000	-1.404	0.000
Difference (inches)	0.069	-0.002	0.014

V4 Downstream Z Value	Z
Measured	80.845
Nominal	80.764
Difference (inches)	0.081

**Description:**

Measured vs. nominal values for V4 flange expressed in the V4 coordinate system.  
 Tol +/- 10mils except for the V4 Z-value. Values in **BOLD** or **RED** are most critical.

**V4 Fiducialization Step: Exit Port**

**Step Fid-3: Post-Installation Check of Exit Port Flange Position**

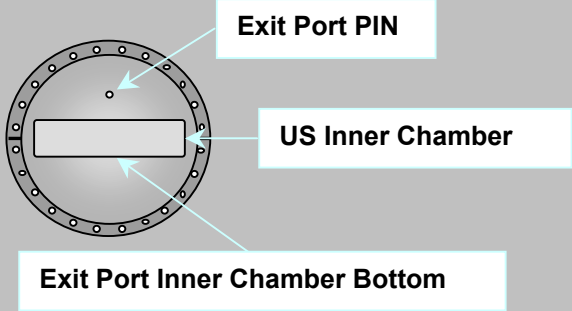

The diagram shows a top-down view of a circular flange with a central rectangular chamber. Three callout boxes with arrows point to specific features: 'Exit Port PIN' points to a small dot on the top edge, 'US Inner Chamber' points to the central rectangular area, and 'Exit Port Inner Chamber Bottom' points to the bottom edge of the chamber.

Exit Port PIN	Z	X	Y
Measured	75.353	4.168	2.300
Nominal	75.000	4.168	2.282
Difference (inches)	0.353	0.000	0.018

Exit Port Inner Chamber Side	Z	X	Y
Measured	75.165	7.428	-0.069
Nominal	75.000	7.418	0.000
Difference (inches)	0.165	0.010	-0.069

Exit Port Inner Chamber Bottom	Z	X	Y
Measured	75.080	4.153	-0.351
Nominal	75.000	0.000	-0.366
Difference (inches)	0.079	4.153	0.015

Exit Port DS Z Value (PART Frame)	Z
Measured	75.883
Nominal	75.768
Difference (inches)	0.115

**Description:**  
 Measured vs. nominal values for Exit Port flange expressed in the EXIT PORT coordinate system.  
 Tol +/- 10mils except for the V4 Z-value. Values in **BOLD** or **RED** are most critical.

**V4 Final Step: Re-Survey of all Ten Fiducials**

Fiducial	Z	X	Y	del Z	del X	del Y
TB1	-34.830	1.437	4.405	0.003	0.000	0.004
TB2	-34.874	8.325	4.407	0.002	0.001	-0.001
TB3	10.974	4.162	2.367	0.001	-0.001	-0.003
TB4	34.547	-4.945	4.374	-0.001	-0.002	-0.003
TB5	36.562	6.226	4.376	-0.002	0.000	-0.002
TB6	52.494	-1.920	2.320	-0.002	0.001	0.001
TB7	55.676	-11.199	3.092	-0.001	0.001	0.001
TB8	59.397	8.948	3.075	-0.002	0.001	0.003
TB9 (V4)	74.649	-20.300	4.410	-0.106	0.018	0.000
TB0 (V4)	77.000	-7.935	4.396	-0.105	0.019	0.000
	inches	inches	inches			

**Description:**  
 Final survey of BM1 standard vacuum chamber. (With V4 and exit port attached.)  
 Note that all comparisons are relative to the most current fiducial values.  
 (I.e. deltas are computed using values from Steps A-1 and Fid-1)

