

**Fiducials for BM1 Std. Vac. Chamber**

**BM1004**

Date:

4/26/02

Chamber:

BM1004

Operator(s):

M. Rogers  
H. Imfeld

Notes:

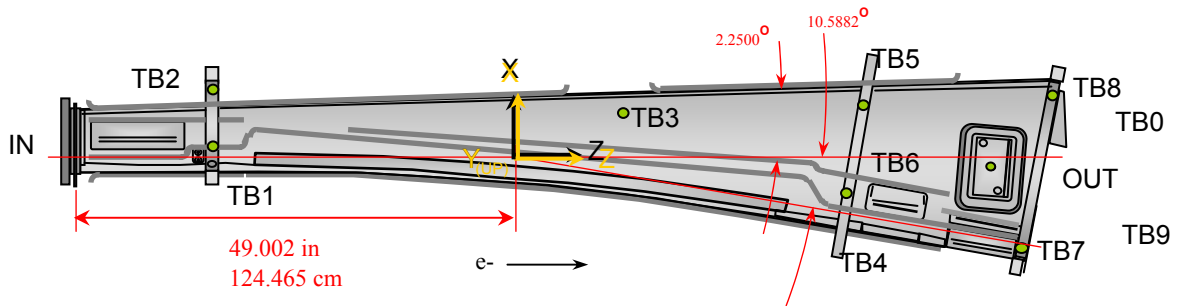

**Fiducial Coordinates for BM1 Standard Vacuum Chamber: (inches)**

Fiducial	Z	X	Y
TB1	-34.831	1.458	4.398
TB2	-34.841	8.458	4.395
TB3	11.076	4.089	2.375
TB4	34.487	-4.990	4.390
TB5	36.609	6.243	4.381
TB6	52.462	-1.881	2.298
TB7	55.656	-11.199	3.047
TB8	59.454	8.962	3.040
TB9 (V4)	74.627	-20.267	4.381
TB0 (V4)	76.881	-8.212	4.380

inches      inches      inches

Nominal Deltas For H3 Absorber (TB6)		
Z	X	Y
52.463	-1.883	2.285
52.493	-1.891	2.242
<b>-0.030</b>	<b>0.008</b>	<b>0.043</b>

Source **V4 Step**

**Description:**

Fid. vals based on internal chamber datum. Source="V4 Step" indicates final data.

Fiducialization Step: (Traveler Step # 1380)

Slot Calibration	
Ideal	0.511
Meas.	0.136
Delta	-0.375

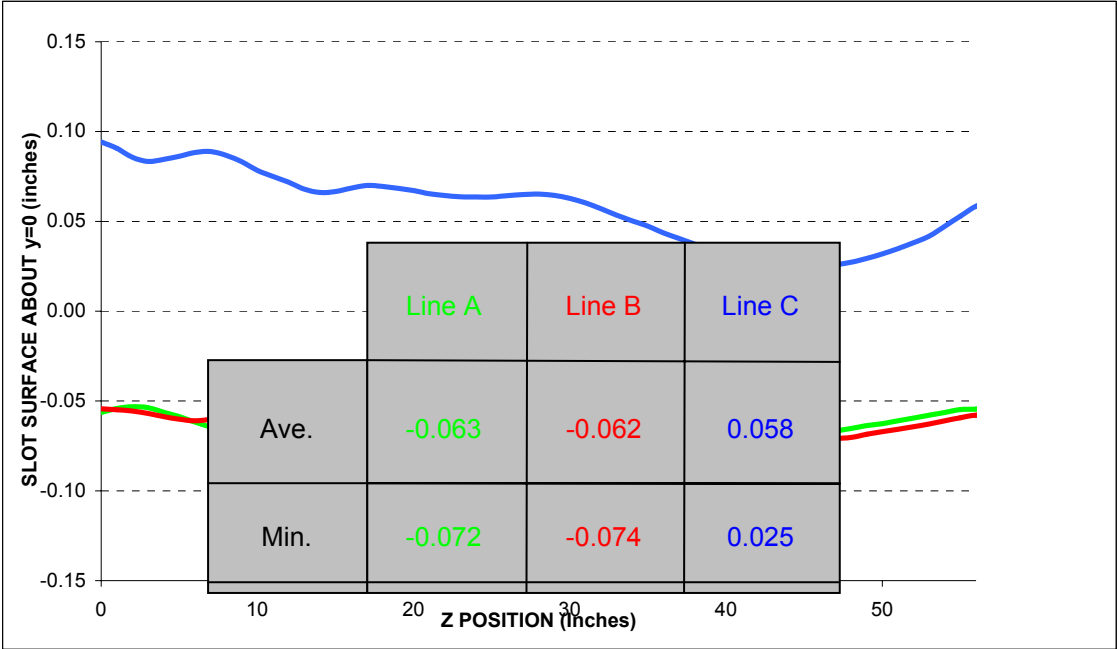

BM1004

**Step 1: Fiducial Coordinates for BM1 Std. Vac. Chamber**

Fiducial	Z	X	Y
TB1	-34.828	1.454	4.398
TB2	-34.846	8.450	4.384
TB3	11.075	4.102	2.369
TB4	34.486	-4.987	4.390
TB5	36.612	6.247	4.381
TB6	52.463	-1.883	2.285
TB7	55.645	-11.197	3.067
TB8	59.457	8.957	3.051
	inches	inches	inches

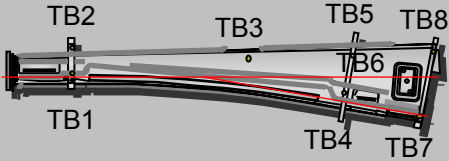

**Description:**  
Fiducial values based on internal chamber datum.

End Surface Attitudes for BM1 Std. Vac. Chamber

Upstream Face		
	yaw	pitch
Measured	2.2	-1.6
<b>Nominal</b>	<b>0.0</b>	<b>0.0</b>
<b>Difference</b>	<b>2.2</b>	<b>-1.6</b>
	mrad	mrad

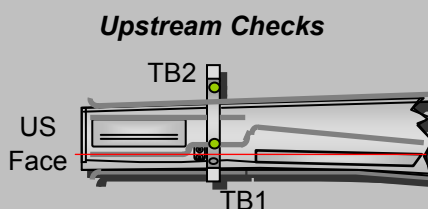

Downstream Port		
	yaw	pitch
Measured	24.9	0.1
<b>Nominal</b>	<b>25.3</b>	<b>0.0</b>
<b>Difference</b>	<b>-0.4</b>	<b>0.1</b>

**Downstream Checks**

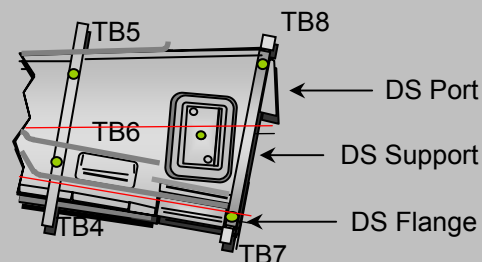

Downstream Support		
	yaw	pitch
Measured	-185.6	-0.6
<b>Nominal</b>	<b>-184.8</b>	<b>0.0</b>
<b>Difference</b>	<b>-0.8</b>	<b>-0.6</b>

Downstream Flange		
	yaw	pitch
Measured	-190.7	-0.4
<b>Nominal</b>	<b>-184.8</b>	<b>0.0</b>
<b>Difference</b>	<b>-5.9</b>	<b>-0.4</b>
	mrad	mrad

**Description:**

Orientation of the upstream and downstream surfaces compared to nominal values. Tol +/- 3 mrad

Datum Verification

DS Support	
	x
Measured	-11.896
<b>Nominal</b>	<b>-11.912</b>
<b>Diff.</b>	<b>0.016</b>
	inches

DS Flange	
	x
Measured	-11.939
<b>Nominal</b>	<b>-11.958</b>
<b>Diff.</b>	<b>0.019</b>
	inches

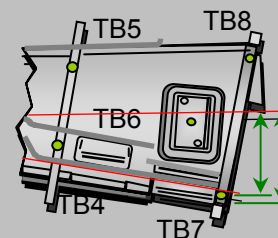

**Description:**

The x-distance from the center-line to the projection of the measured DS inside curve point on either of the DS surfaces. Tolerance values +/- 0.020 in.

BM1004  
Status

<u>BM1 Chamber Lengths</u>			Nominal Length
Tangent Line:	Length 58.559 inches	without SMR	58.558 <span style="background-color: green; color: white; padding: 2px;">OK</span>
Orbit Line:	Length 57.498 inches	without SMR	57.569 <span style="background-color: green; color: white; padding: 2px;">OK</span>
<b>Description:</b> Both lengths are to the faces of the weld flanges. Length tolerance +/- 0.125 in.			

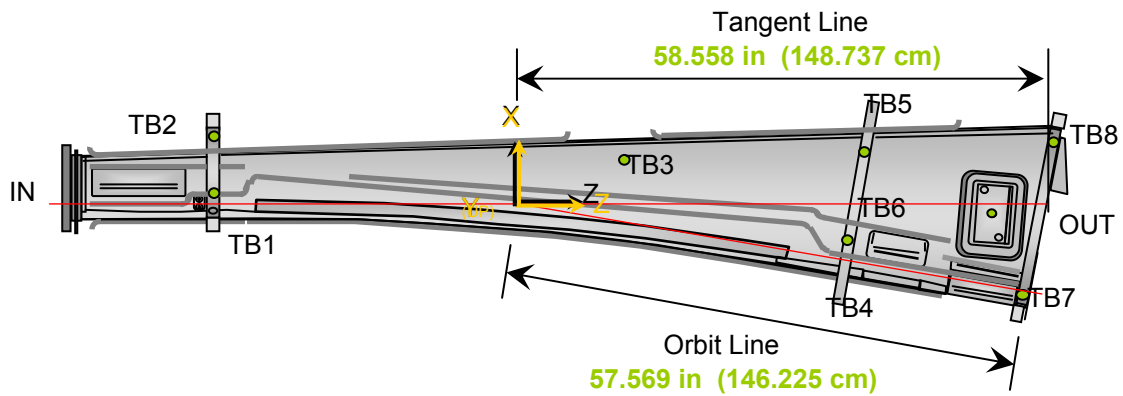

**V4 Step A: Survey and Check of BM1 Standard Vacuum Chamber Fiducials Before Attaching V4 and the Exit Port:**

**Step A-1: Remeasurement of Fiducial Coordinates for BM1 Std. Vac. Chamber**

Fiducial	Z	X	Y	del Z	del X	del Y
TB1	-34.827	1.458	4.398	0.001	0.004	0.001
TB2	-34.835	8.457	4.395	0.011	0.007	0.011
TB3	11.078	4.090	2.367	0.003	-0.012	-0.002
TB4	34.487	-4.990	4.390	0.000	-0.003	0.000
TB5	36.608	6.243	4.381	-0.004	-0.004	-0.001
TB6	52.460	-1.880	2.294	-0.003	0.003	0.008
TB7	55.652	-11.201	3.065	0.007	-0.004	-0.001
TB8	59.450	8.964	3.061	-0.007	0.007	0.009

inches      inches      inches

Compared to Step 1 Fiducial Coords.

**DS Port Level Check**

Level Status: OK

OK ?  (YES or NO)

**US Flange Roll Check**

Roll Status: UPDATE

OK ?  (YES or NO)

**Description:**  
Fid. vals based on internal chamber datum.

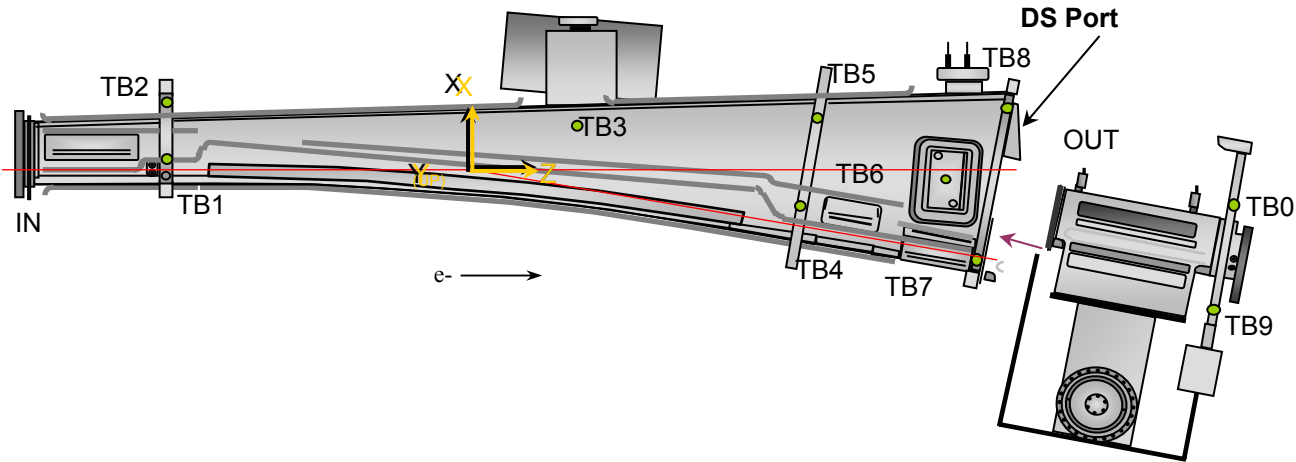

**V4 Step A:** Check of US Flange Prior to V4 Installation

**Step A-2: Pre-Installation Check of UpStream Flange Postion**

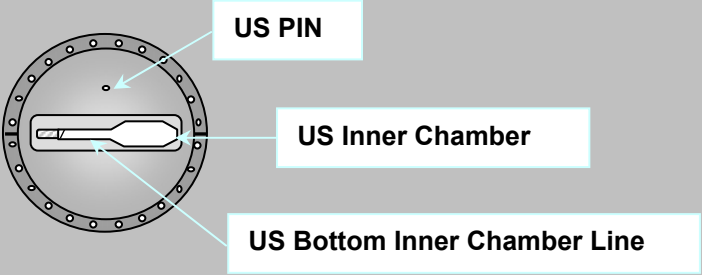

US PIN	Z	X	Y
Measured	-50.860	1.842	2.332
Nominal	-51.000	1.836	2.282
Difference (inches)	0.140	0.006	0.050

US Inner Chamber	Z	X	Y
Measured	-50.597	-1.402	-0.003
Nominal	-51.000	-1.404	0.000
Difference (inches)	0.403	0.002	-0.003

US Bottom Inner Chamber Line	ROLL	(FINAL)
Measured	-0.838	
Nominal	0.000	
Difference (mrads)	-0.838	

Roll Status **OK**

**Description:**  
Measured vs. nominal values for US flange expressed in the PART coordinate system.  
Fiducial values are updated (using those from Step A-1) if ROLL delta is not within 1 mrad.

**V4 Fiducialization Step: Survey of Fiducial Coordinates for BM1 Standard Vacuum Chamber with V4 and the Exit Port Attached:**

**Step Fid-1: Position of Added Tooling Balls TB9 and TB0**

Fiducial	Z	X	Y
TB9 (V4)	74.601	-20.262	4.384
TB0 (V4)	76.871	-8.210	4.379
	inches	inches	inches

**Description:**  
Fid. vals after V4 and exit port attached.

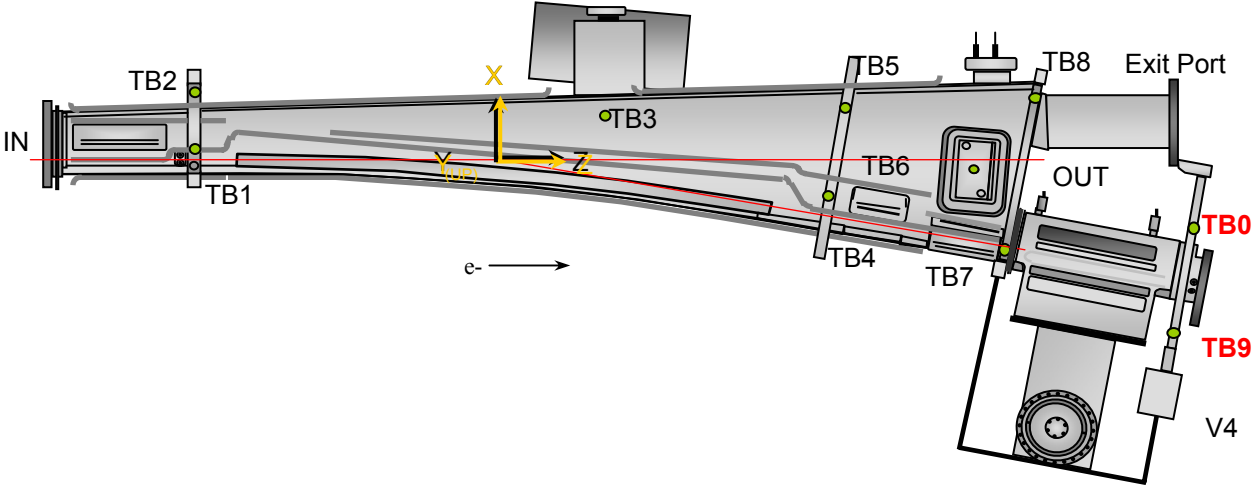

**V4 Fiducialization Step: V4 Flange**

**Step Fid-2: Set Position of V4 Flange Position**

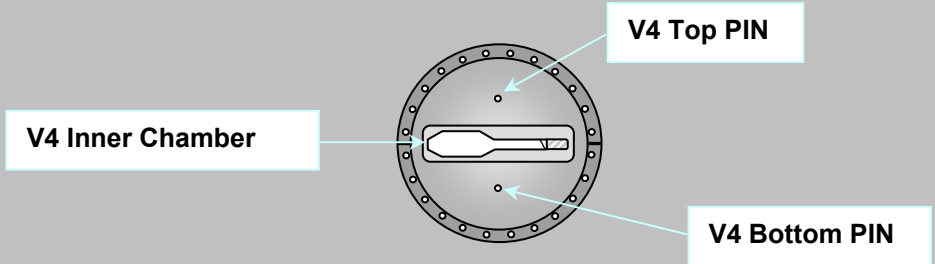

V4 Top PIN	Z	X	Y
Measured	80.160	0.000	2.278
Nominal	80.000	0.000	2.282
Difference (inches)	0.159	<b>0.000</b>	<b>-0.004</b>

V4 Bottom PIN	Z	X	Y
Measured	80.158	0.003	-2.286
Nominal	80.000	0.000	-2.282
Difference (inches)	0.158	<b>0.003</b>	<b>-0.004</b>

V4 Inner Chamber	Z	X	Y
Measured	79.901	-1.405	-0.012
Nominal	80.000	-1.404	0.000
Difference (inches)	-0.099	<b>-0.001</b>	-0.012

V4 Downstream Z Value	Z
Measured	80.688
Nominal	80.764
Difference (inches)	<b>-0.076</b>

**Description:**

Measured vs. nominal values for V4 flange expressed in the V4 coordinate system.  
 Tol +/- 10mils except for the V4 Z-value. Values in **BOLD** or **RED** are most critical.

**V4 Fiducialization Step: Exit Port**

**Step Fid-3: Post-Installation Check of Exit Port Flange Position**

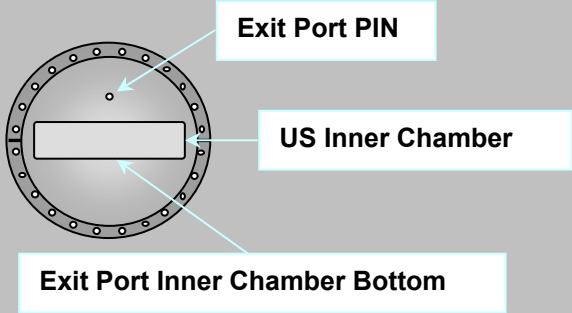

The diagram shows a circular flange with a central rectangular chamber. Three callouts point to specific features: 'Exit Port PIN' points to a small dot on the top edge, 'US Inner Chamber' points to the central rectangular area, and 'Exit Port Inner Chamber Bottom' points to the bottom edge of the chamber.

Exit Port PIN	Z	X	Y
Measured	75.304	4.160	2.277
Nominal	75.000	4.168	2.282
Difference (inches)	0.304	-0.008	-0.005

Exit Port Inner Chamber Side	Z	X	Y
Measured	74.984	7.409	0.115
Nominal	75.000	7.418	0.000
Difference (inches)	-0.016	-0.009	0.115

Exit Port Inner Chamber Bottom	Z	X	Y
Measured	74.964	4.363	-0.368
Nominal	75.000	0.000	-0.366
Difference (inches)	-0.036	4.363	-0.002

Exit Port DS Z Value (PART Frame)	Z
Measured	75.822
Nominal	75.768
Difference (inches)	0.054

**Description:**  
 Measured vs. nominal values for Exit Port flange expressed in the EXIT PORT coordinate system.  
 Tol +/- 10mils except for the V4 Z-value. Values in **BOLD** or **RED** are most critical.

**V4 Final Step: Re-Survey of all Ten Fiducials**

Fiducial	Z	X	Y	del Z	del X	del Y
TB1	-34.831	1.458	4.398	-0.004	0.000	0.000
TB2	-34.841	8.458	4.395	-0.005	0.001	0.000
TB3	11.076	4.089	2.375	-0.002	-0.001	0.008
TB4	34.487	-4.990	4.390	0.000	0.000	0.000
TB5	36.609	6.243	4.381	0.001	0.000	0.000
TB6	52.462	-1.881	2.298	0.002	-0.001	0.005
TB7	55.656	-11.199	3.047	0.004	0.002	-0.018
TB8	59.454	8.962	3.040	0.004	-0.002	-0.021
TB9 (V4)	74.627	-20.267	4.381	0.025	-0.005	-0.003
TB0 (V4)	76.881	-8.212	4.380	0.010	-0.002	0.001
	inches	inches	inches			

**Description:**  
 Final survey of BM1 standard vacuum chamber. (With V4 and exit port attached.)  
 Note that all comparisons are relative to the most current fiducial values.  
 (I.e. deltas are computed using values from Steps A-1 and Fid-1)

