

**Fiducials for BM1 Std. Vac. Chamber**

**BM1001**

Date:

3/7/02

Chamber:

BM1001

Operator(s):

H. Imfeld

J. McDougal

Notes:

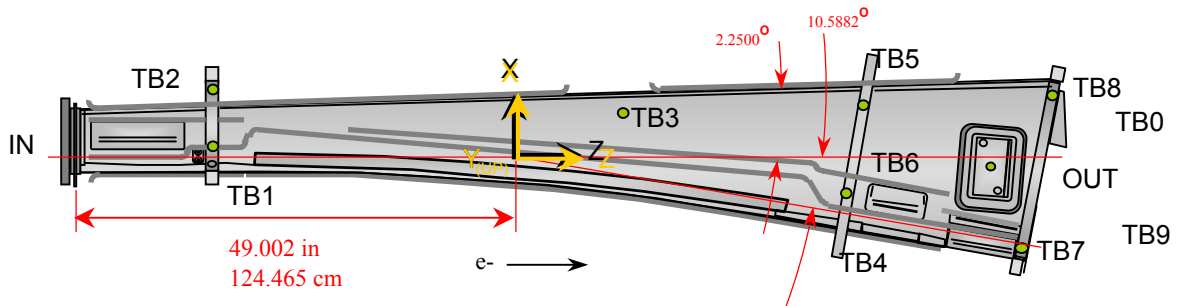

**Fiducial Coordinates for BM1 Standard Vacuum Chamber: (inches)**

Fiducial	Z	X	Y
TB1	-34.846	1.577	4.396
TB2	-34.865	8.473	4.401
TB3	10.941	4.391	2.343
TB4	34.504	-4.877	4.379
TB5	36.613	6.251	4.375
TB6	52.467	-1.862	2.274
TB7	55.677	-11.181	3.014
TB8	59.483	8.960	3.031
TB9 (V4)	74.670	-20.226	4.374
TB0 (V4)	76.958	-7.990	4.386

inches      inches      inches

**Nominal Deltas For H3 Absorber (TB6)**

Z	X	Y
52.469	-1.873	2.266
52.493	-1.891	2.242
<b>-0.025</b>	<b>0.018</b>	<b>0.024</b>

Source **V4 Step**

**Description:**

Fid. vals based on internal chamber datum. Source="V4 Step" indicates final data.

Fiducialization Step: (Traveler Step # 1380)

Slot Calibration	
Ideal	0.511
Meas.	0.145
Delta	-0.366

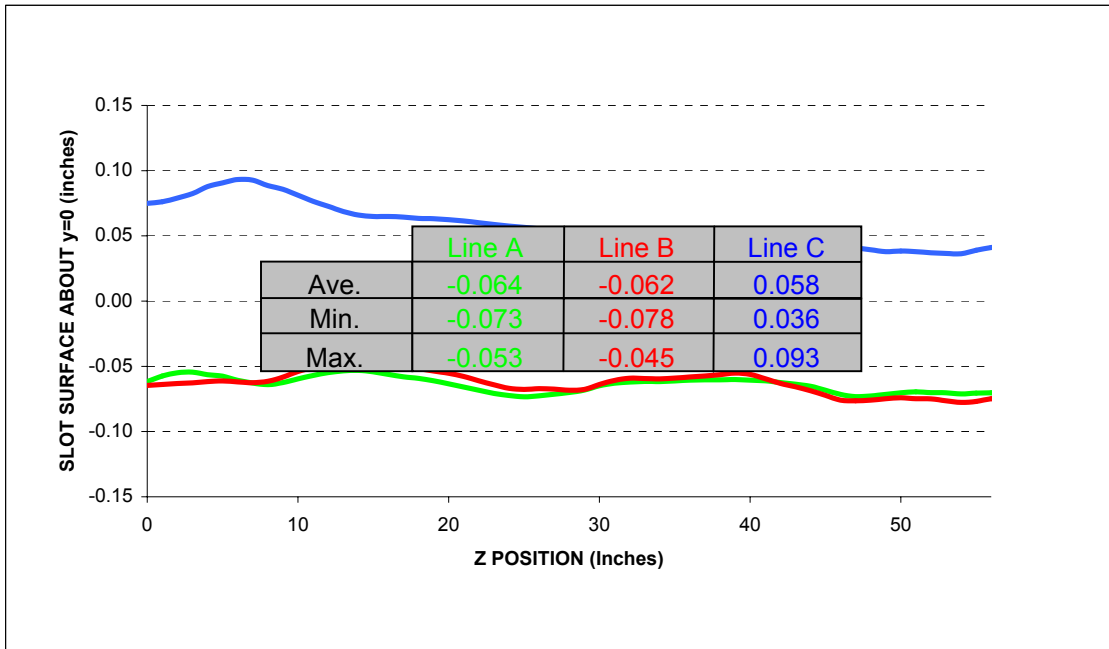

BM1001

**Step 1: Fiducial Coordinates for BM1 Std. Vac. Chamber**

Fiducial	Z	X	Y
TB1	-34.850	1.576	4.397
TB2	-34.868	8.473	4.400
TB3	10.938	4.409	2.354
TB4	34.504	-4.876	4.379
TB5	36.620	6.250	4.375
TB6	52.469	-1.873	2.266
TB7	55.669	-11.195	3.005
TB8	59.483	8.945	3.028
	inches	inches	inches

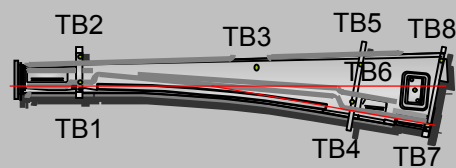

**Description:**

Fiducial values based on internal chamber datum.

End Surface Attitudes for BM1 Std. Vac. Chamber

Upstream Face		
	yaw	pitch
Measured	4.9	6.4
Nominal	0.0	0.0
Difference	4.9	6.4
	mrad	mrad

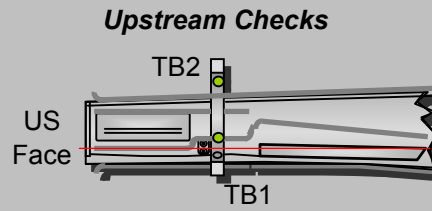

Downstream Port		
	yaw	pitch
Measured	23.8	6.1
Nominal	25.3	0.0
Difference	-1.5	6.1

**Downstream Checks**

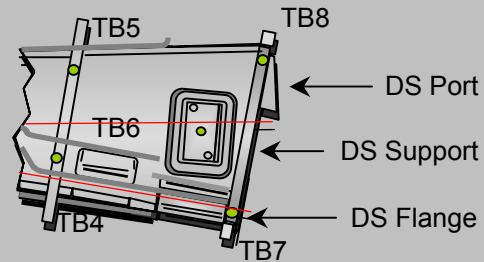

Downstream Support		
	yaw	pitch
Measured	-186.6	7.1
Nominal	-184.8	0.0
Difference	-1.8	7.1

Downstream Flange		
	yaw	pitch
Measured	-191.6	9.0
Nominal	-184.8	0.0
Difference	-6.8	9.0
	mrad	mrad

**Description:**

Orientation of the upstream and downstream surfaces compared to nominal values. Tol +/- 3 mrad

Datum Verification

DS Support	
	x
Measured	-11.913
Nominal	-11.912
Diff.	-0.001
	inches

DS Flange	
	x
Measured	-11.956
Nominal	-11.958
Diff.	0.002
	inches

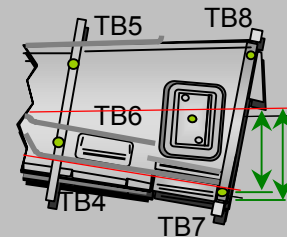

**Description:**

The x-distance from the center-line to the projection of the measured DS inside curve point on either of the DS surfaces. Tolerance values +/- 0.020 in.

BM1001  
Status

<u>BM1 Chamber Lengths</u>			Nominal Length	
Tangent Line:	Length 58.558 inches	without SMR	58.558	OK
Orbit Line:	Length 57.488 inches	without SMR	57.569	OK

**Description:**  
Both lengths are to the faces of the weld flanges.  
Length tolerance +/- 0.125 in.

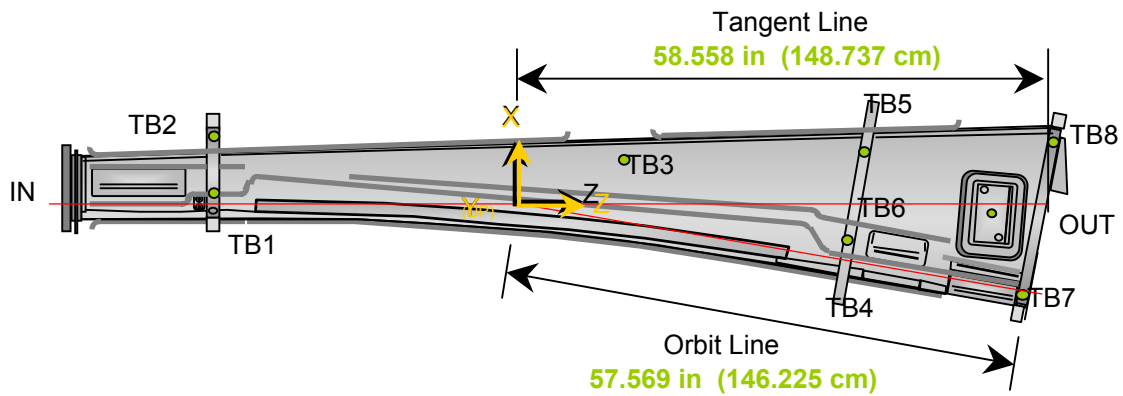

**V4 Step A: Survey and Check of BM1 Standard Vacuum Chamber Fiducials Before Attaching V4 and the Exit Port:**

**Step A-1: Remeasurement of Fiducial Coordinates for BM1 Std. Vac. Chamber**

Fiducial	Z	X	Y	del Z	del X	del Y
TB1	-34.846	1.576	4.396	0.005	0.000	0.000
TB2	-34.866	8.474	4.401	0.002	0.001	0.001
TB3	10.939	4.391	2.344	0.002	-0.018	-0.010
TB4	34.505	-4.877	4.380	0.001	-0.001	0.001
TB5	36.613	6.251	4.375	-0.007	0.001	-0.001
TB6						
TB7	55.676	-11.180	3.010	0.006	0.015	0.005
TB8	59.476	8.963	3.024	-0.007	0.018	-0.004
	inches	inches	inches	Compared to Step 1 Fiducial Coords.		

**DS Port Level Check**

OK ?  (YES or NO)

Level Status: OK

**US Flange Roll Check**

OK ?  (YES or NO)

Roll Status: OK

**Description:**  
Fid. vals based on internal chamber datum.

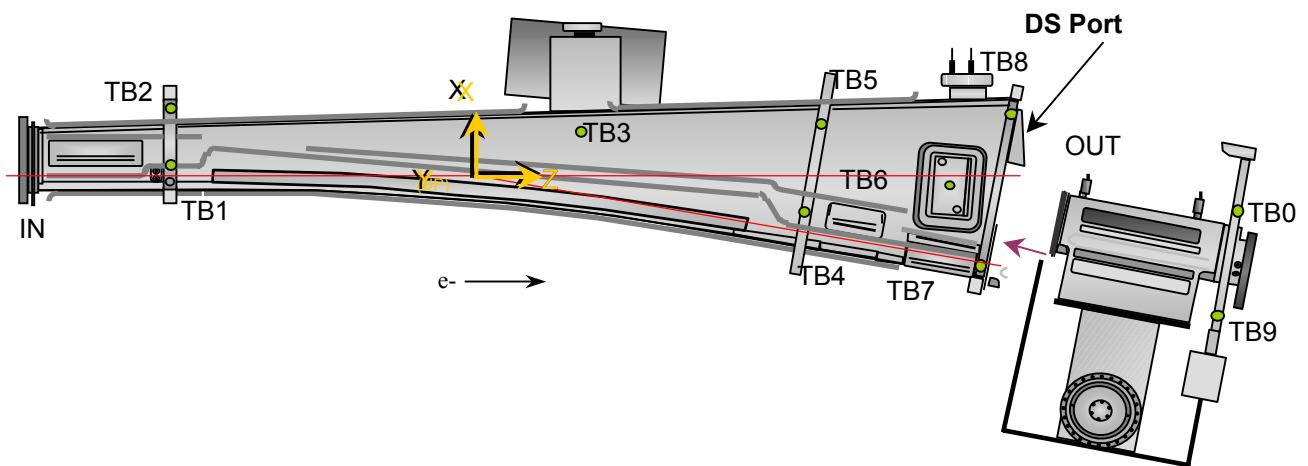

**V4 Step A:** Check of US Flange Prior to V4 Installation

**Step A-2: Pre-Installation Check of UpStream Flange Position**

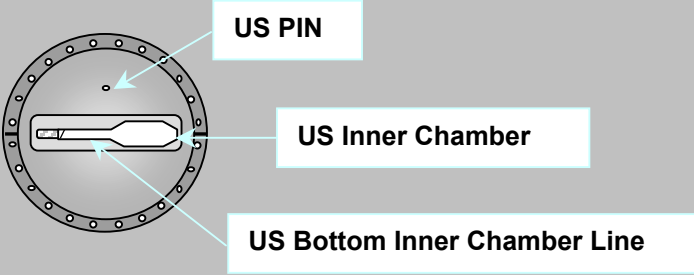

The diagram shows a top-down view of a circular flange with a central rectangular chamber. A small dot is labeled 'US PIN'. The central chamber is labeled 'US Inner Chamber'. A horizontal line at the bottom of the inner chamber is labeled 'US Bottom Inner Chamber Line'.

US PIN	Z	X	Y
Measured	-50.847	1.855	2.315
Nominal	-51.000	1.836	2.282
Difference (inches)	0.153	0.019	0.033

US Inner Chamber	Z	X	Y
Measured	-50.627	-1.389	0.012
Nominal	-51.000	-1.404	0.000
Difference (inches)	0.373	0.015	0.012

US Bottom Inner Chamber Line	ROLL	(FINAL)
Measured	-0.076	
Nominal	0.000	
Difference (mrads)	-0.076	

Roll Status **OK**

**Description:**  
 Measured vs. nominal values for US flange expressed in the PART coordinate system.  
 Fiducial values are updated (using those from Step A-1) if ROLL delta is not within 1 mrad.

**V4 Fiducialization Step: Survey of Fiducial Coordinates for BM1 Standard Vacuum Chamber with V4 and the Exit Port Attached:**

**Step Fid-1: Position of Added Tooling Balls TB9 and TB0**

Fiducial	Z	X	Y
TB9 (V4)	74.692	-20.228	4.376
TB0 (V4)	76.977	-7.993	4.389
	inches	inches	inches

**Description:**  
Fid. vals after V4 and exit port attached.

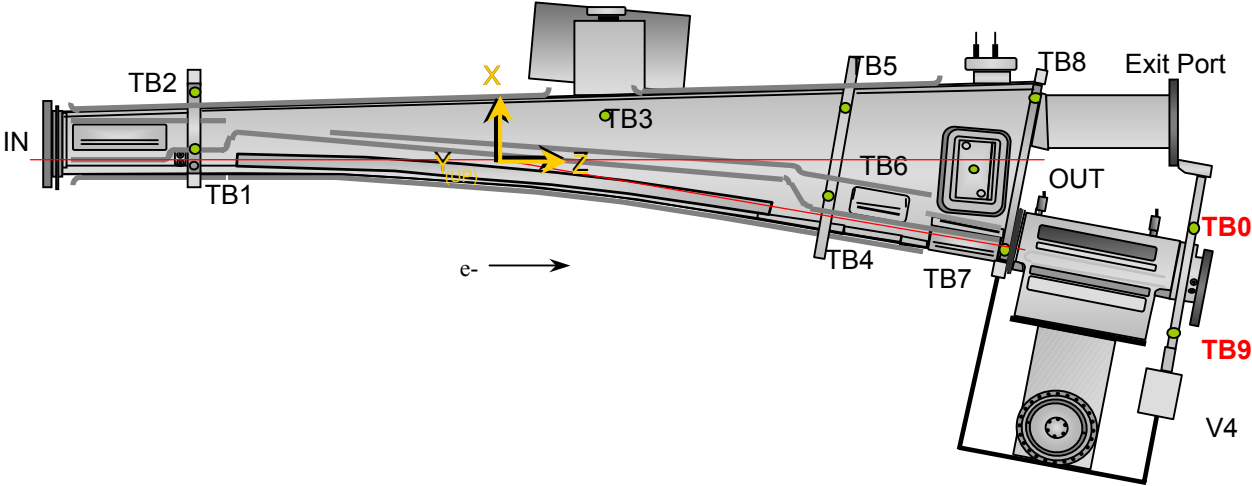

**V4 Fiducialization Step: V4 Flange**

**Step Fid-2: Set Position of V4 Flange Position**

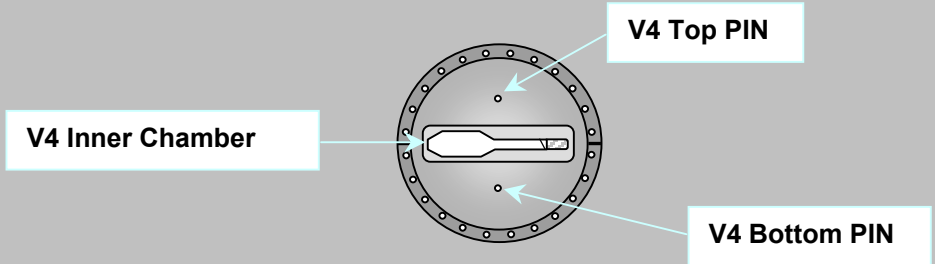

V4 Top PIN	Z	X	Y
Measured	80.216	0.004	2.281
Nominal	80.000	0.000	2.282
Difference (inches)	0.216	<b>0.004</b>	<b>-0.001</b>

V4 Bottom PIN	Z	X	Y
Measured	80.207	0.000	-2.279
Nominal	80.000	0.000	-2.282
Difference (inches)	0.207	<b>0.000</b>	<b>0.003</b>

V4 Inner Chamber	Z	X	Y
Measured	79.935	-1.406	-0.057
Nominal	80.000	-1.404	0.000
Difference (inches)	-0.065	<b>-0.002</b>	-0.057

V4 Downstream Z Value	Z
Measured	80.748
Nominal	80.764
Difference (inches)	<b>-0.016</b>

**Description:**

Measured vs. nominal values for V4 flange expressed in the V4 coordinate system.  
 Tol +/- 10mils except for the V4 Z-value. Values in **BOLD** or **RED** are most critical.

**V4 Fiducialization Step: Exit Port**

**Step Fid-3: Post-Installation Check of Exit Port Flange Position**

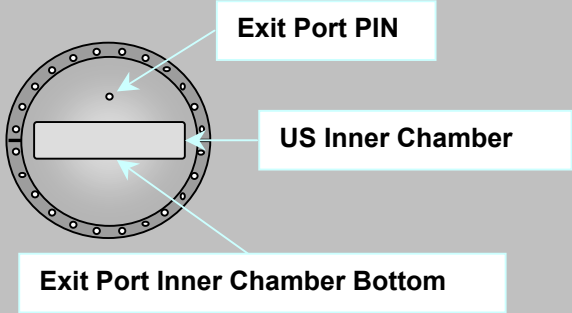

The diagram shows a top-down view of a circular flange with a central rectangular chamber. Three callout boxes with arrows point to specific features: 'Exit Port PIN' points to a small dot on the top edge, 'US Inner Chamber' points to the central rectangular area, and 'Exit Port Inner Chamber Bottom' points to the bottom edge of the chamber.

Exit Port PIN	Z	X	Y
Measured	75.319	4.163	2.296
Nominal	75.000	4.168	2.282
Difference (inches)	0.319	<b>-0.005</b>	<b>0.014</b>

Exit Port Inner Chamber Side	Z	X	Y
Measured	75.146	7.422	0.225
Nominal	75.000	7.418	0.000
Difference (inches)	0.146	<b>0.004</b>	0.225

Exit Port Inner Chamber Bottom	Z	X	Y
Measured	75.027	4.099	-0.355
Nominal	75.000	0.000	-0.366
Difference (inches)	0.027	4.099	<b>0.011</b>

Exit Port DS Z Value (PART Frame)	Z
Measured	75.881
Nominal	75.768
Difference (inches)	<b>0.113</b>

**Description:**  
 Measured vs. nominal values for Exit Port flange expressed in the EXIT PORT coordinate system.  
 Tol +/- 10mils except for the V4 Z-value. Values in **BOLD** or **RED** are most critical.

**V4 Final Step: Re-Survey of all Ten Fiducials**

Fiducial	Z	X	Y	del Z	del X	del Y
TB1	-34.846	1.577	4.396	0.000	0.001	0.000
TB2	-34.865	8.473	4.401	0.001	-0.001	0.000
TB3	10.941	4.391	2.343	0.001	0.000	-0.002
TB4	34.504	-4.877	4.379	-0.001	0.000	0.000
TB5	36.613	6.251	4.375	0.000	0.000	0.000
TB6	52.467	-1.862	2.274			
TB7	55.677	-11.181	3.014	0.001	-0.002	0.004
TB8	59.483	8.960	3.031	0.006	-0.002	0.006
TB9 (V4)	74.670	-20.226	4.374	-0.022	0.002	-0.002
TB0 (V4)	76.958	-7.990	4.386	-0.019	0.003	-0.003

inches          inches          inches

**Description:**  
Final survey of BM1 standard vacuum chamber. (With V4 and exit port attached.)  
Note that all comparisons are relative to the most current fiducial values.  
(I.e. deltas are computed using values from Steps A-1 and Fid-1)

