

Gradient Dipole Magnet Checks	145D15
--------------------------------------	---------------

Date: <input style="width: 80%;" type="text" value="8/16/01"/>	Magnet: <input style="width: 80%;" type="text" value="145D15"/>	Operators: <input style="width: 80%;" type="text" value="M. Rogers"/> <input style="width: 80%;" type="text" value="L. Juarez"/>
Notes: <div style="border: 1px solid black; padding: 10px; min-height: 40px; color: red; font-weight: bold; margin-top: 10px;">Magnetic vs. Mechanical offset NOT applied (June 2002)</div>		

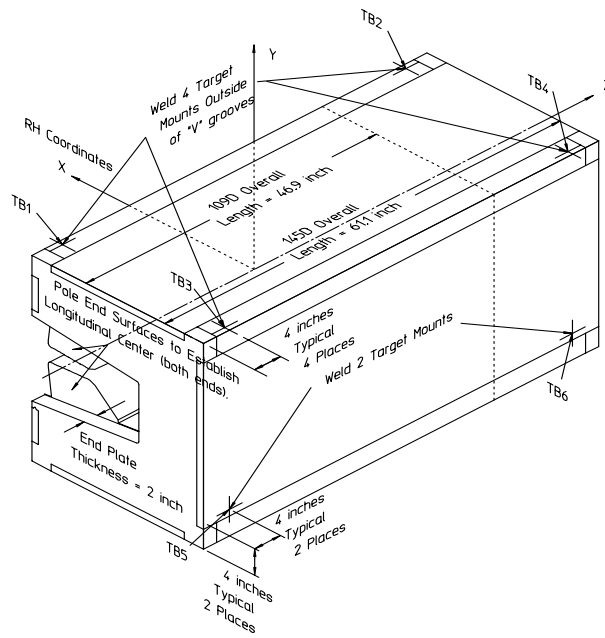

Magnetic Fiducial Coordinates: (inches)

Fiducial	Z	X	Y	
TB1	-26.5207	3.4390	17.0016	Offset: <input style="width: 80%;" type="text" value="0.0006"/> inches
TB2	26.5489	3.4418	17.0046	
TB3	-26.5291	-22.4244	16.9991	
TB4	26.5205	-22.4220	17.0043	
TB5	-26.5156	-24.2711	-11.5731	
TB6	26.5541	-24.2721	-11.6528	

Description:
Fiducial values based on the x-offset of the mechanical center line to the magnetic.

Downstream Garage Mechanical Check:

145D15
Status

Horizontal (X) 0.094 mm	Vertical (Y) -0.049 mm	X-value:	OK
		Y-value:	OK
<p>Description: How much does the Z-axis from the US garage miss the center of the DS garage?</p>			

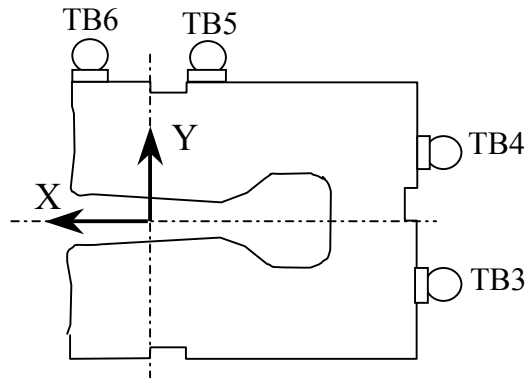

Trolley Checks:

145D15
Status

<u>Trolley Distance</u>			
3D Distance R1 2800.196 mm	3D Distance R2 2800.150 mm	R2 - R1 (mm) -0.046	OK
<p>Description: Travel distance for trolley target points should be similar. If not, trolley (rails) may be skewed.</p>			

<u>Z-axis Vector</u>			
3D Angle Yaw 0.0231	Pitch 0.0131	0.0190 mrad	Midpoint 3D Offset (mm) 0.032
<p>Description: Angle between R1 and R2 vectors. The average of these two defines the Z-axis.</p>			

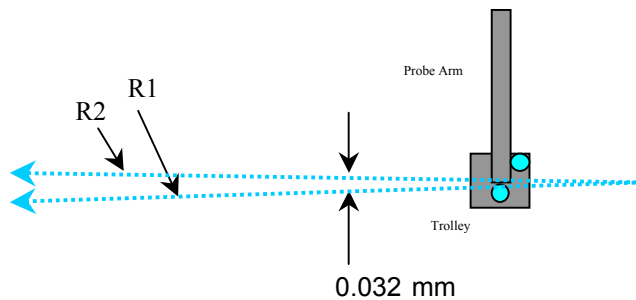

Wire Holder Position Checks:

145D15
Status

<u>Wire Holders' Yaw Check</u>		<u>W2 - W1 (mm)</u>	
3D Distance W1 2383.116 mm	3D Distance W2 2382.846 mm	-0.270	OK
Description: Distance between wire holders for TB1 and TB2.			

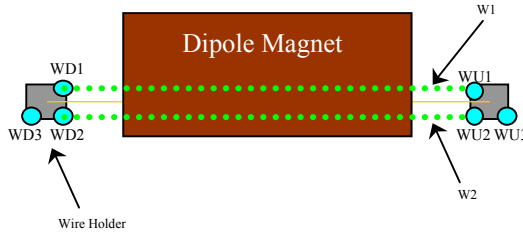

Wire Position Checks:

145D15
Status

<u>Wire Orientation</u>			<u>Midpoint 3D Offset (mm)</u>	
3D Angle 0.0531	Yaw 0.0218	Pitch -0.0484 mrad	0.063	OK
Description: Orientation of wire with respect to Z-axis defining axis of dipole.				

<u>Wire Offsets</u>			<u>Origin Offset:</u>	
US -0.010	Origin 0.016	DS 0.041 mm		OK
Description: Offset distance from the mechanical center to the wire. (x-offsets only!)				

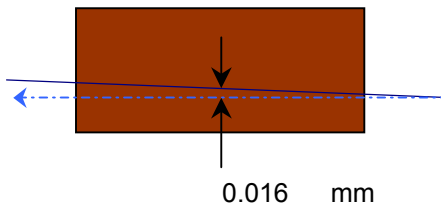

End Surface Orientation Check and Magnet Length:

145D15
Status

<u>End Surfaces</u>					
	3D Angle	Yaw	Pitch		
US:	1.9758	-1.5354	1.2436	mrad	
DS:	1.6128	-1.2689	0.9955		
				3D Offset (mm)	
				~ 1.324	Too Big?
				~ 1.081	Too Big?
Description:					
End surface orientation relative to reference frame.					
Note: 3D Offset based on average of width and height of the magnet side.					

<u>Length of Magnet</u>			
Distance with SMR	Distance		
1590.047 mm	1551.947 mm		OK
Description:			
Length of magnet along Z-axis. (Design vals: 1551.61 and 1189.10)			

Top Surface Orientation Check:

145D15
Status

<u>Top of Magnet</u>					
Height (Y-value) with 0.75"		Delta Y			
Corner 1	412.848 mm		0.097	Delta Y C1:	OK
Corner 2	412.882 mm		0.131	Delta Y C2:	OK
Corner 3	412.751 mm		0.000	Delta Y C3:	OK
Corner 4	412.825 mm		0.074	Delta Y C4:	OK
Dispersion:					
Corner 1	0.105 mm				
Corner 2	0.072 mm				
Corner 3	0.077 mm				
Corner 4	0.048 mm				
Overall	0.081 mm				
3D Angle	Roll	Pitch		Roll (mm)	
0.1450	0.1398	-0.0383	mrad	~ 0.075	OK
Twist:		Roll	Pitch	Pitch (mm)	
		0.0741	0.0258	~ -0.059	OK
		0.040	0.040	mm	
Twist:				Twist:	OK
Description:					
Top surface corner heights and average surface orientation values. (With 0.75" SMR offset.)					

Back Surface Orientation Check:

145D15
Status

<u>Back of Magnet</u>					
Horizontal (X-value)		Delta X			
US:	115.684	mm		0.000	
Origin:	115.716	mm		0.032	
DS:	115.747	mm		0.063	
3D Angle		Roll	Yaw		
	0.1767	0.1710	0.0445	mrad	
				<u>Midpoint</u>	
				<u>Yaw in mm</u>	
				0.035	OK
Description:					
Position of scanned half of back surface of magnet for yaw check. (With 0.75" SMR offset.)					

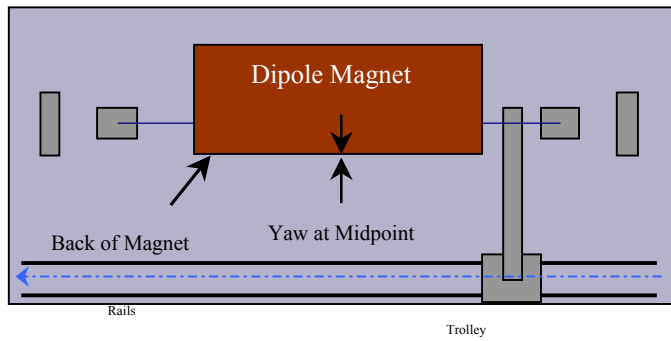

**Gradient Magnet
Magnetic Measurements/Fiducialization Traveller**

Approval must be obtained before going on to the next procedure
or removing the magnet from the test stand.

Magnetic Measurements Approval by – Jack Tanabe or Nanyang Li

Fiducialization Approval by – Jack Tanabe or Tony King

Magnet Serial Number: 145D15

Capacitive System Alignment

Date _____, Operator _____

Fiducial Measurements

See Data Sheet on Next Page.

Approval:

Date: 8/16/01 Operator: M. Rogers

--

Water, Power and Interlock Connections.

Date _____, Operator _____

Measured Water Flow _____ gpm at $\Delta p =$ _____ psi

Maximum Conditioning Current: _____ Amps

Wire Magnetic Measurements

Currents _____

Summary File Name(s) _____

Date _____, Operator _____ Approval _____

Coil Magnetic Measurements: Required _____ Yes _____ No.

Currents _____

Summary File Name(s) _____

Date _____, Operator _____ Approval _____

**Gradient Magnet
Reduced Data Sheet**

Approval must be obtained before removing magnet from test stand.
Magnetic Measurements Approval by – Jack Tanabe or Tony King.

Magnet Serial Number: 145D15

Magnetic Measurements Operator: _____ Date: _____

Measured Magnetic Center Offset: 0.016 mm

Measured at:

Integrated Field: _____ T-m @ _____ Amps

Corrected to:

Integrated Field: XX.XXX T-m @ XXX.XXX Amps

Fiducialization:

Operator(s): M. Rogers L. Juarez

Date: 8/16/01 Temp: 22 deg. C

Fiducial - Measured	z mm	x mm	y mm
TB1	-673.626	87.351	431.841
TB2	674.343	87.421	431.916
TB3	-673.840	-569.581	431.777
TB4	673.620	-569.520	431.908
TB5	-673.495	-616.485	-293.956
TB6	674.473	-616.511	-295.981

Fiducial - Magnetic	z mm	x mm	y mm
TB1	-673.626	87.351	431.841
TB2	674.343	87.421	431.916
TB3	-673.840	-569.581	431.777
TB4	673.620	-569.520	431.908
TB5	-673.495	-616.485	-293.956
TB6	674.473	-616.511	-295.981

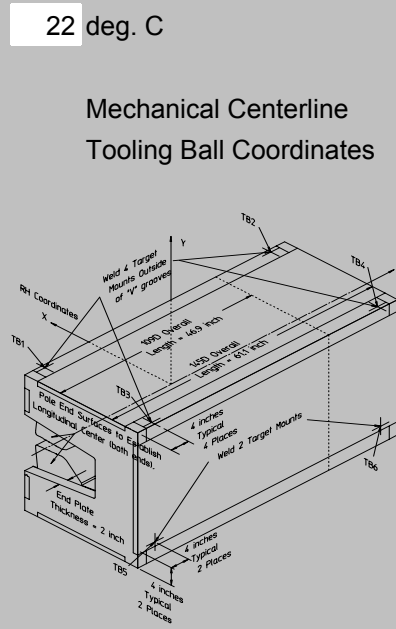

Magnetic Centerline
Tooling Ball Coordinates

Check Measurements:

Corner	X _{measured} mm	X _{nominal} mm
C1	96.634	96.520
C2	96.697	96.520

incl. paint no paint

	Y _{measured} mm	Y _{nominal} mm
C1	393.798	393.700
C2	393.832	393.700
C3	393.701	393.700
C4	393.775	393.700

incl. paint no paint

Approval: