

THE DRAWINGS, SPECIFICATIONS AND OTHER DATA HEREIN PROVIDED SHALL NOT BE COPIED, PUBLISHED OR OTHERWISE FURTHER DISSEMINATED WITHOUT PRIOR WRITTEN PERMISSION OF STANFORD UNIVERSITY/SLAC

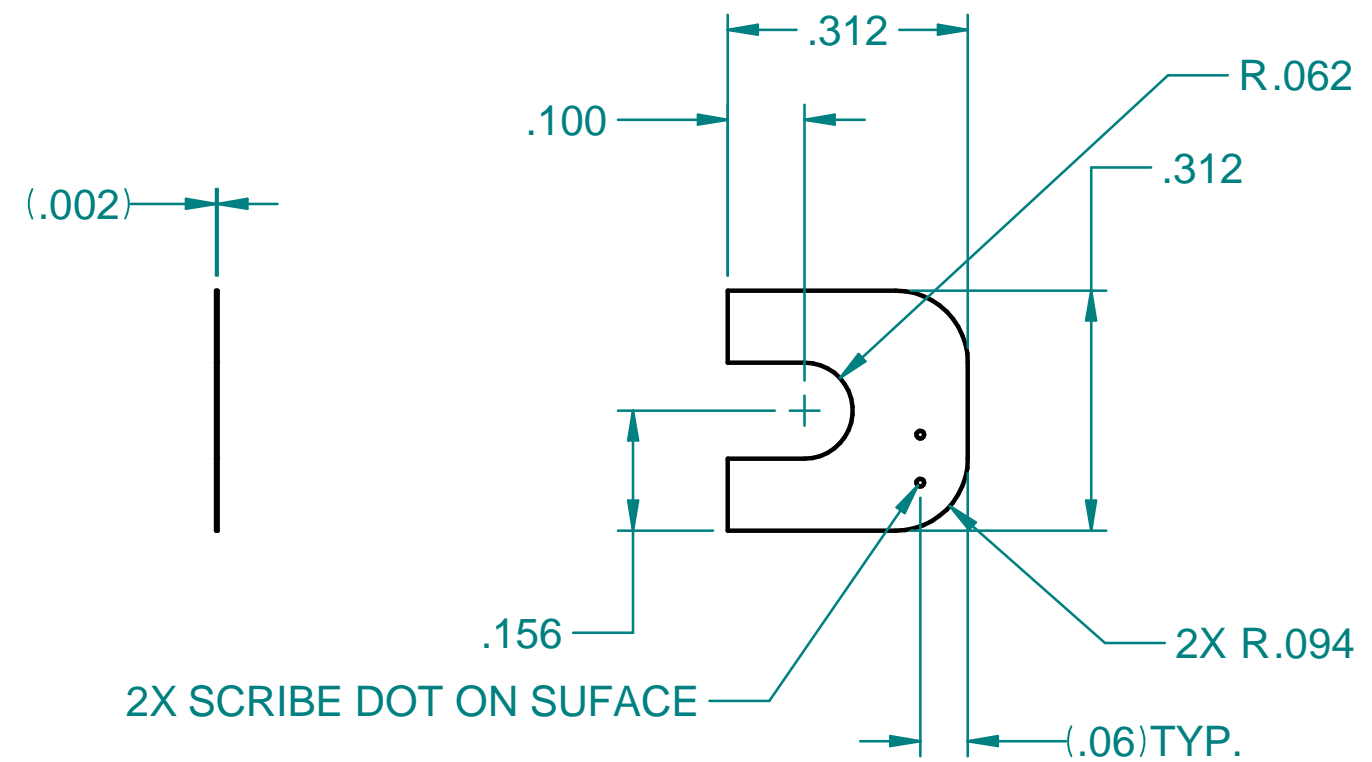

PF-381-905-62 0 B

REV	DESCRIPTION	DWN	CHKR	APVD	DATE
-----	-------------	-----	------	------	------



NOTES: UNLESS OTHERWISE SPECIFIED
 1 BAG AND LABEL WITH PART NUMBER AND REVISION.

	SHIM STOCK .002 THK. BRASS
STOCK NO	MATERIAL DESCRIPTION

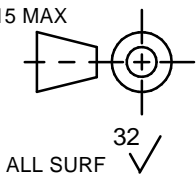
---	SCALE: 4:1 DO NOT SCALE DRAWING		CAD FILE NAME: pf38190562-0.dft
---	DIMENSIONING AND TOLERANCING IS IAW ASME Y14.5M-1994 AND Y14.41-2003	 	LCLS MAGNET SYSTEM MAGNET CASSETTE ASSY MAG BLK SHIM .002 ---
---	UNLESS OTHERWISE SPECIFIED DIMENSIONS ARE IN INCHES. TOLERANCES: BREAK EDGES .005-.015 INTERNAL CORNERS R.015 MAX		
SA-381-905-54	FRACTIONS ± --- DEC .XX ± --- .XXX ± .005 .XXXX ± ---	ENGR T. MONTAGNE DWN J. STIEBER 3/20/12 CHKR T. MONTAGNE	
SA-381-905-53	ANGLE ± --- ALL SURF 	APPROVALS T. MONTAGNE --- J. STIEBER ---	
NEXT ASSEMBLIES:			DRAWING NUMBER PF-381-905-62 REVISION NUMBER 0 B

LCLS MAG CASSETTE SHIM .002

1 OF 1 SHEET