

# LCLS-II Undulator Test Plan

Zachary Wolf<sup>a</sup>, Yurii Levashov<sup>a</sup>, Heinz-Dieter Nuhn<sup>a</sup>, Erik Wallen<sup>b</sup>, Diego Arbelaez<sup>b</sup>

<sup>a</sup>Stanford Linear Accelerator Center

<sup>b</sup>Lawrence Berkeley National Laboratory

October 14, 2016

## Abstract

This note presents the test plan for the LCLS-II hard x-ray and soft x-ray undulators. The undulators will be measured and tuned in the Magnetic Measurement Facility at SLAC and in the Undulator Measurement Facility at LBNL. The requirements of the tuning are well established and are summarized in this note. A brief discussion of the measurement equipment is presented. This is followed by the detailed test plan in which each step is enumerated. Finally, the measurement results and data storage format are presented.

## 1 Introduction<sup>1</sup>

The LCLS-II will have 34 undulator segments for the hard x-ray line (HXR) and 22 undulator segments for the soft x-ray line (SXR). Hereafter, the undulator segments will be referred to as undulators. These numbers include one spare SXR undulator and two spare HXR undulators. There will be no designated reference undulator of the LCLS-II type, instead we will use fixed gap LCLS-I undulators as reference undulators. The first undulator received of each type will be set aside for the duration of the measurements and will be measured several times in order to verify that the undulators in the storage area remain within specifications. The undulators must be tuned to meet strict requirements. They must also be fiducialized to allow alignment with other components. This note details the plan for tuning and fiducializing the LCLS-II undulators.

The note begins by describing how LBNL and SLAC will share the undulator tuning responsibilities. The laboratories in which the work will be performed and the relevant equipment is then briefly described. The list of tuning and fiducialization requirements is presented. This is followed by a detailed test plan in which all the steps of tuning and fiducialization are enumerated.

## 2 SLAC And LBNL Work Sharing And Facilities

Tuning of the HXR undulators will be shared between LBNL and SLAC. Approximately two thirds of the HXR undulators will be tuned at LBNL, with the rest of the HXR and

---

<sup>1</sup>Work supported in part by the DOE Contract DE-AC02-76SF00515. This work was performed in support of the LCLS project at SLAC.

all the SXR undulators being tuned at SLAC. All undulators will have their final data sets and fiducialization done at SLAC.

The undulator test plan described here relies on SLAC and LBNL having proper facilities to perform the work. In order to meet the undulator tuning specifications and schedule, the testing facilities will need to have the following attributes.

The SLAC magnetic measurements group has two high precision measurement benches for tuning undulators and for making final data sets as discussed below. The benches are located in the Magnetic Measurement Facility (MMF). The MMF has 0.1 °C temperature stability at a set point variable from 17 °C to 23 °C. Most measurements will take place at 20.0 °C, but the variable set point will allow studies of temperature effects on the undulators. The benches are located on deep foundations to ensure vibration isolation and bench alignment stability. In addition, the foundations are wide enough to hold both the bench and the undulator under test in order to maintain relative alignment. Proper undulator handling infrastructure will be provided such as cranes, forklifts, smooth floors, and powered movers, the details to be determined. Proper laboratory equipment is provided such as a light duty crane for handling support pedestals and long measurement coils, a complete set of instruments, calibration equipment, etc. Hall probe calibrations for both SLAC and LBNL will be done at SLAC. Storage space for at least two undulators will be part of the laboratory to allow undulators to come to temperature before testing. Storage space for receiving undulators and for storing them until they are needed for installation is provided adjacent to the MMF. Storage space for the reference undulators will be provided in the main measurement laboratory.

The LBNL magnetic measurements group will have one high precision measurement bench for undulator tuning. It is located in new laboratory space. The temperature requirements, bench foundations, undulator handling infrastructure, laboratory equipment, and undulator storage space needs are the same as mentioned above for the SLAC laboratory. In addition, LBNL must provide safe undulator transportation to SLAC. Both temperature and shock must be regulated so that the undulator tuning done at LBNL is not changed when the undulator arrives at SLAC. If an undulator arrives at SLAC significantly out of tolerance, it should be returned to LBNL for repair.

SLAC will be responsible for storing undulators from the time they are tuned until they are placed in the tunnel. The storage location must maintain  $\pm 15$  °C temperature stability so that the undulators are not damaged by thermal expansion effects or by demagnetization effects. The storage location must also provide humidity control and contamination control. SLAC will provide all undulator transportation on the SLAC site.

LBNL will be responsible for accepting undulators at the factory. The factory will set up a mechanical inspection area in which each undulator is tested to make sure its mechanisms perform properly, linear encoders perform properly, no poles protrude too far into the gap, etc. In addition, a quick magnetic check will be performed to make sure each pole has the right magnetic polarity. The SXR undulators will be shipped directly from the factory to SLAC. SLAC will do initial acceptance tests to make sure the undulators are not damaged in shipping. The test plan for acceptance will be provided by LBNL. The HXR undulators will be shipped to LBNL and initial acceptance tests will be done there. Final acceptance will occur after magnetic measurements and tuning. If an undulator fails the acceptance test or is not tunable, consult project management about how to proceed.

### 3 Undulator Measurement Precision

FEL performance relies on all undulators in the system having precise K values relative to each other. There are additional requirements, but this one is the most demanding. Systematic errors are tolerated in the K values, as long as they are the same for all undulators in the line. To keep the systematic errors as constant as possible, all undulators in a given line will have their final data sets and fiducialization done on the same bench with the same instruments, frequent calibrations, and devices to check the consistency of the measurements. The benches used for final data sets will be located at SLAC in order to minimize potential changes before installation.

Having one bench perform final data set measurements is an important step in meeting the tolerances, but it is not sufficient. The bench must make both precise and accurate measurements so that if an instrument breaks, it can be replaced without affecting the measurement results. Detailed calibrations will be made at SLAC and reference magnets will be used to monitor probe drifts. This plan is the same as used in LCLS-I.<sup>2</sup>

### 4 Earth's Field

The Earth's field is different in the tunnel than in the measurement lab. LCLS-I experience shows that differences of 0.2 G should be expected. The permeable material in the undulator poles will amplify this difference in the undulator gap by a factor of about 2. The difference in the Earth's field is large enough to bring the undulator out of tolerance for the field integrals.

In order to minimize the difference in the Earth's field between the measurement lab and the tunnel, the SLAC benches are oriented parallel to the tunnel. The tuning and final data sets will be made with the undulator in the same orientation as it will have in the tunnel. The layout of the tunnel and the laboratory is shown in figure 1.

The Earth's field in the LBNL measurement lab has been measured and compared to the field in the SLAC measurement lab. For the HXR undulators that will be tuned at LBNL, the difference in the Earth's field compared to SLAC is minimal since the LBNL bench has very similar orientation to the HXR SLAC bench. This will minimize the corrections needed at SLAC before the final data set measurements.

To account for the expected 0.2 G difference between the MMF and the tunnel, a Helmholtz coil will be set up in the MMF. One or more undulators of each type will be put in the Helmholtz coil and the field integrals will be measured as a function of applied field. The applied field simulates the field difference between the MMF and the tunnel.

The Earth's field difference will be corrected by correction coil windings on the beam pipe. The corrector current settings will be calibrated in the MMF. The Earth's field in the tunnel will be mapped and compared to the Earth's field in the measurement lab for each undulator location. In this way, the corrector current settings will be determined for each undulator location.

As a final check, if time permits, each undulator will have its field integrals measured in the tunnel as close as possible to its final location. If this is not possible, one undulator

---

<sup>2</sup>Z. Wolf, Y. Levashov, H.-D. Nuhn, and I. Vasserman, "LCLS Undulator Test Plan", LCLS-TN-06-17, December, 2006.

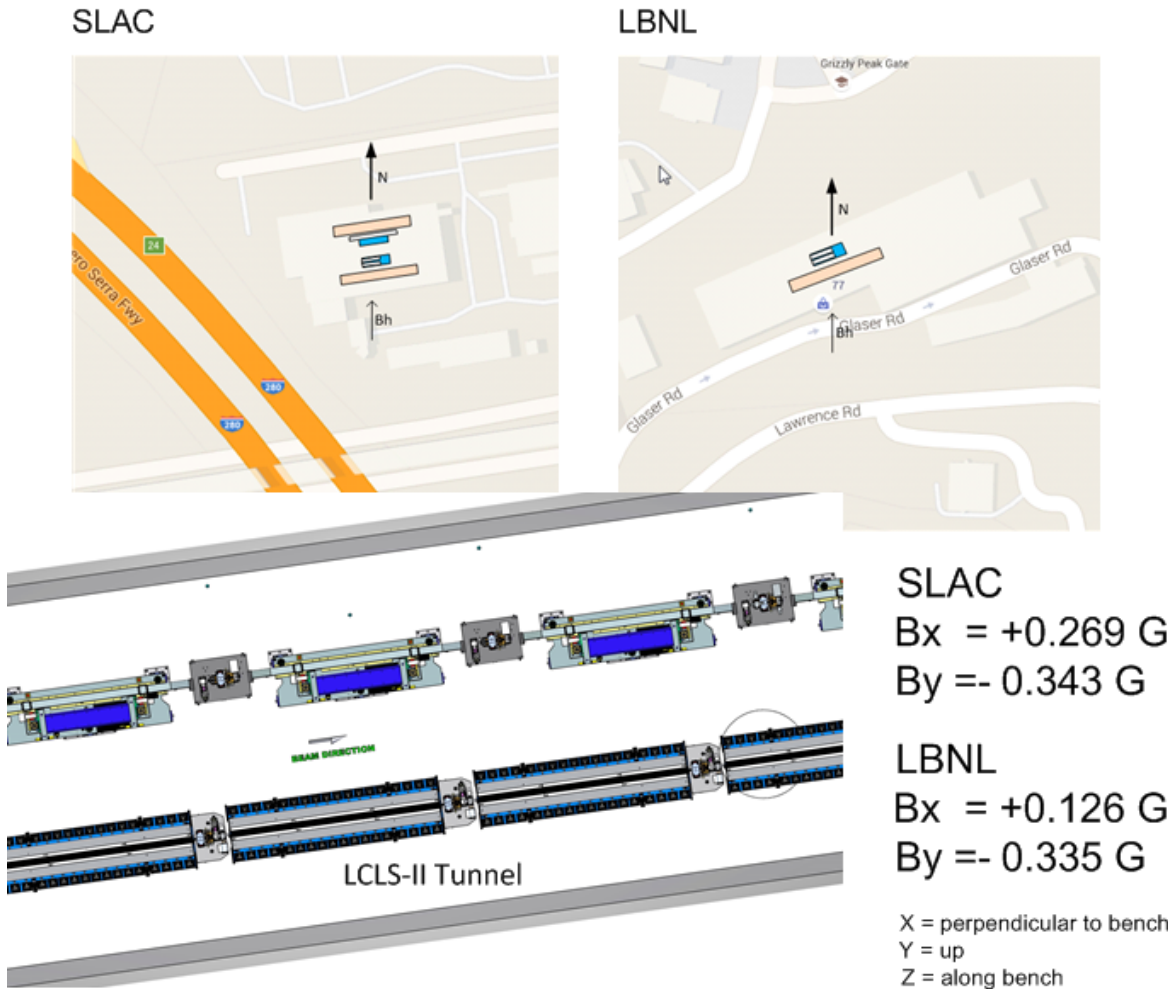

Figure 1: This figure shows the layout of the MMF so that the undulators have the same orientation in the lab as in the tunnel.

may be used for this measurement and moved to each location. The field integrals will be measured and should agree with measurements in which the Helmholtz coil was set to the difference in the Earth's field between the tunnel and the lab at that location. Fine adjustments to the corrector current settings will be determined at this time, if required.

## 5 Undulator Tuning Requirements

The LCLS-II undulator tuning and fiducialization requirements come from an undulator Physics Requirements Document<sup>3</sup>. The list of tuning and fiducialization requirements are briefly summarized below.

<sup>3</sup>H. D. Nuhn et al., "Undulator System Requirements", LCLS-II Physics Requirements Document LCLSII-3.2-PR-0038-R2.

## 5.1 HXR Tuning Requirements

The undulator will be primarily tuned at a gap of 9 mm, but the requirements must be met for all gaps in the operating range of 7.2 to 20 mm. The field integral tolerances given below must be met for all horizontal and vertical positions within  $\pm 1.0$  mm of the undulator beam axis. The  $K$  value and phase tolerances must be met on the undulator beam axis.

1. The  $K$  value must be known to  $\pm 2.3 \times 10^{-4}$  at all gap settings. The  $K$  value will be measured at a discrete set of gaps. A fit to the measured  $K$  value vs. gap data must allow  $K$  values at intermediate points to be known within the tolerance given here. This requirement sets the density of the measurements as a function of gap.
2. The phase shake in each undulator must be less than 4 degrees rms.
3. The total phase advance in the 4.012667 meter long cell must be known to  $\pm 5$  degrees.
4. Phase matching the undulator requires knowing two terms, an entrance and an exit phase advance<sup>4</sup>. Both of these terms must be known to  $\pm 3.5$  degrees.
5. The first field integral of  $B_x$  and  $B_y$  must be within  $\pm 40 \times 10^{-6}$  Tm. The second field integral of  $B_x$  and  $B_y$  must be within  $\pm 150 \times 10^{-6}$  Tm<sup>2</sup>.
6. The undulator temperature at which all measurements are performed must be  $20.0 \pm 0.1$  degrees Celsius.
7. The position of the beam axis must be known to  $\pm 50$   $\mu\text{m}$  in  $x$  and  $\pm 200$   $\mu\text{m}$  in  $y$  relative to tooling balls on the undulator when the undulator is set at the tuning gap.

## 5.2 SXR Requirements

The undulator will be primarily tuned at a gap of 10 mm, but the requirements must be met for all gaps in the operating range of 7.2 to 22 mm. The field integral tolerances given below must be met for all horizontal and vertical positions within  $\pm 1.0$  mm of the undulator beam axis. The  $K$  value and phase tolerances must be met on the undulator beam axis.

1. The  $K$  value must be known to  $\pm 3 \times 10^{-4}$  at all gap settings. The  $K$  value will be measured at a discrete set of gaps. A fit to the measured  $K$  value vs. gap data must allow  $K$  values at intermediate points to be known within the tolerance given here. This requirement sets the density of the measurements as a function of gap.
2. The phase shake in each undulator must be less than 5 degrees rms.
3. The total phase advance in the 4.400000 meter long cell must be known to  $\pm 10$  degrees.
4. The phase matching error at both the entrance and the exit of the undulator must be less than  $\pm 7$  degrees.
5. The first field integral of  $B_x$  and  $B_y$  must be within  $\pm 40 \times 10^{-6}$  Tm. The second field integral of  $B_x$  and  $B_y$  must be within  $\pm 150 \times 10^{-6}$  Tm<sup>2</sup>.

---

<sup>4</sup>Z. Wolf, "Phase Matching The LCLS-II Undulators", LCLS-TN-16-3, July, 2016.

6. The undulator temperature at which all measurements are performed must be  $20.0 \pm 0.1$  degrees Celsius.
7. The position of the beam axis must be known to  $\pm 300 \mu\text{m}$  in  $x$  and  $\pm 100 \mu\text{m}$  in  $y$  relative to tooling balls on the undulator when the undulator is set at the tuning gap.

### 5.3 Operational Requirements

We impose the following operational requirements.

1. The reference undulator must be measured after every 4'th undulator. At this time, the alignment of the measurement benches must also be checked.
2. A reference magnet at the bench must be measured with the Hall probe and this measurement compared to an NMR measurement before each final data set. The Hall probe must be recalibrated when its measurement relative to the NMR changes by more than  $1 \times 10^{-4}$ .
3. No magnetic shield will be used on the undulators. A Helmholtz coil must be set up for both the HXR and SXR undulators to study the effect of changes in the Earth's field between the laboratory and the tunnel.
4. A corrector on the beam pipe must be characterized to determine the current settings required to correct the differences in the Earth's field as the gap is changed.
5. A commissioning gap will be chosen based on the first article. Estimates of the commissioning gap are given in the Physics Requirements Document<sup>5</sup>. At the commissioning gap, phase matching shims will be inserted at the undulator ends. In this way, the undulator lines can be commissioned with the phase shifters off.
6. After tuning, the undulators will be stored until they are placed in the tunnel. Every four months, an undulator must be returned from storage and inspected and measured to verify that the storage conditions are not altering the undulator. Temperature and humidity must be logged in the undulator storage area.
7. After all undulators are measured, one undulator of each type will remain in the lab for a temperature test. The  $K$  value will be measured over the range  $18 \text{ }^\circ\text{C}$  to  $22 \text{ }^\circ\text{C}$  in  $1 \text{ }^\circ\text{C}$  steps. These measurements will be used to determine corrections to the gap settings for tunnel temperatures different than  $20.0 \text{ }^\circ\text{C}$ .
8. One undulator of each type will be transported to the LCLS-II tunnel and then returned to the MMF for re-measurement. This test is to ensure that undulator handling practices do not change the  $K$  calibration.

---

<sup>5</sup>H. D. Nuhn et al., "Undulator System Requirements", LCLS-II Physics Requirements Document LCLSII-3.2-PR-0038-R2.

## 5.4 Measurement Requirements

Each bench will use capacitive sensors to align the undulator to the bench at the minimum undulator gap. In this way, since the capacitive sensors will fit within the minimum gap, they will never interfere with the undulator and will not need to be removed for other measurements. Hall probes will be used for most of the magnetic measurements. A long coil or flip coil will be used for overall field integral and field uniformity measurements. The undulator fiducialization will occur at the bench for the SXR undulators using a laser tracker. The HXR undulator fiducialization will take place using a combination of measurements at the bench and on the CMM. Sets of fiducialization magnets and reference poles on stands at the ends of the undulator will be used as checks to avoid fiducialization errors. Optical alignment equipment will be used to check the fiducialization. Vertical and horizontal field alignment magnets are used to set the probe angles. Vertical and horizontal reference magnets are used to check the Hall probe calibration. A touch probe will be used to give mechanical gap measurements at each pole for a set of gap encoder readings.

At SLAC, each Hall probe measurement starts in a zero Gauss chamber and ends in a zero Gauss chamber. There is minimal field in these chambers, so any non-zero reading is due to offsets in the probe electronics. A linear fit is made to the beginning and end measurements in the zero Gauss chambers and the fit is subtracted from the measurements in the undulator as a zero offset correction. LBNL will use one zero Gauss chamber and each measurement will start in the zero Gauss chamber to determine the zero offset correction.

## 6 Tuning Test Plan

### 6.1 Overview

The undulator tuning is done in several stages. When an undulator is delivered to the MMF, an acceptance test will be performed. In addition to the acceptance test, all limit switch settings will be made and all encoder offset values will be determined so that the undulator is protected and operational when it is moved into the lab for tuning. Before tuning, the undulator must sit in a temperature stabilization area for at least two days. For tuning, the undulator is brought to a bench and aligned. Measurements are made at the tuning gap and other gaps and an algorithm from LBNL is used to choose different shim types to minimize the field integrals at all gaps. Phase errors will be minimized at the tuning gap. After the tuning, the gap is changed to the commissioning gap giving a prescribed  $K$  value, and phase matching shims are added at the ends so that the phase shifters can be turned off when  $K$  has this value. The gap is then varied and the undulator parameters are measured as a function of gap. When the tolerances are met at all gaps, a final data set will be made and the undulator will be fiducialized.

### 6.2 Test Plan

1. Preliminaries

- (a) All undulators must have their limit switch positions set and their encoder offsets set before entering the tuning laboratory. The undulator must be protected and

functional.

- (b) The undulator must be at  $20 \pm 0.5$  °C when it is moved to the bench. During the setup time and initial tuning, the undulator must come to a temperature of  $20 \pm 0.1$  °C.
- (c) At SLAC, the HXR undulators will initially be placed on the CMM before tuning in order to check for mechanical imperfections. The necessity of this step will be evaluated after checking several undulators. Similar measurements will be done for the SXR undulators, but with a touch probe on the measurement bench.
- (d) The HXR undulators have three possible positions for placing the girder on the pedestals. The first two undulators, after they are tuned, will be measured at each of the three positions in order to study the effect of shifting the mounting positions. The remaining undulators will be tuned and measured with the position that the undulator will have in the tunnel.

## 2. Place the undulator

- (a) Bolt an SXR undulator to the floor at the SXR measurement bench. Place an HXR undulator plus its girder on the pedestals permanently installed at the HXR bench.
- (b) Make all necessary wiring connections to operate the undulator. Test all limit switches.
- (c) Attach thermistors to measure temperature.

## 3. Mechanically align the undulator to the bench

- (a) Set the undulator gap to the minimum value.
- (b) Have an alignment crew roughly place the undulator so the probes go through it without touching.
- (c) Use capacitive sensors to measure the undulator position.
- (d) Use the position adjustments to move the undulator into final position. At this point, the mechanical center line is 1.4 meters above the floor and it is at a fixed location away from the bench all the way down the bench.

## 4. Magnetically align the Hall probe to the undulator

- (a) Set the undulator gap to the tuning gap.
- (b) Measure along the undulator with the Hall probe to find the pole positions.
- (c) At every  $N$ 'th pole ( $N \simeq 5$ ), move the Hall probe in  $x$  and  $y$  and find the magnetic center. Alternatively, perform scans at several  $x$  and  $y$  locations and determine the magnetic center at each pole from the scans. Fit the magnetic field centers as a function of  $z$ . Move the probe to the field center line.
- (d) Correct pitch and yaw of the magnetic center line with the position adjustments, if necessary, and repeat step (c).



- (e) The magnetic center line defines  $x = 0$ ,  $y = 0$  for the Hall probe position. This line will be the beam axis.
5. Trajectory and phase tuning
 

Tune the x trajectory, y trajectory, and the phase. Use the LBNL software which chooses shim combinations and shim positions based on several measurements at different gaps and different x-positions. Minimize phase errors at the tuning gap.
  6. Check the gap dependence of the tuning
    - (a) Check the trajectory straightness and phase errors at gaps ranging from the minimum gap to the maximum operating gap in steps of 2 mm.
    - (b) If the trajectories are not straight or the phase errors grow out of tolerance at gaps other than the tuning gap, either continue the tuning with the LBNL software, or use the shim signatures to place appropriate shims so that trajectory and phase shake tolerances are met at all gaps in the operating range.
  7. Adjust the gap dependence of the field integrals
    - (a) Set up the long coil at  $x = 0$ ,  $y = 0$ .
    - (b) At the tuning gap, measure the field integrals of both  $B_x$  and  $B_y$  with a long coil.
    - (c) Use trajectory shims at the entrance to null the second field integrals.
    - (d) Use trajectory shims at the exit to null the first field integrals.
    - (e) Repeat these steps in an iterative way at the minimum gap, at the maximum operating gap, and at the tuning gap until the field integrals are within tolerance at all three gaps.
  8. Adjust the field integral uniformity
    - (a) At the tuning gap, use the long coil to measure the field integrals at  $y = 0$  as a function of  $x$  at  $x = -1, -0.5, 0, 0.5, 1$  mm.
    - (b) Add quadrupole and sextupole shims to bring those terms within tolerance.
    - (c) Measure the field integrals at  $x = 0$  as a function of  $y$  at  $y = -1, -0.5, 0, 0.5, 1$  mm.
    - (d) Add skew quadrupole and skew sextupole shims to bring those terms within tolerance.
    - (e) Repeat these steps in an iterative way at the minimum gap, at the maximum operating gap, and at the tuning gap until the field integrals are within tolerance at all three gaps.
  9. Measure the  $K$  uniformity

- (a) With the Hall probe, measure the  $K$  value at  $y = 0$ ,  $x = -200, -100, 0, 100, 200$   $\mu\text{m}$  and  $x = 0$ ,  $y = -200, -100, 0, 100, 200$   $\mu\text{m}$ .
  - (b) Verify that the second derivative of  $K$  vs position meets the falloff tolerance. If this condition is not met, consult the undulator physicist.
10. Find the commissioning gap
- After the tuning is done, measure at several gaps near the gap which gives the commissioning  $K$  value (to be determined). Fit the measurements and determine the gap which gives the commissioning  $K$  value.
11. Add phase matching shims
- (a) Set the gap to the value which gives the commissioning  $K$  value. Measure and calculate the phase advance from the middle of the break section to each of the poles from the 5'th pole at the entrance to the 5'th pole from the exit. Subtract the ideal phase at each pole<sup>6</sup>. Average to find the phase matching error over these poles. Add phase matching shims at the entrance to make the phase matching error equal to zero. Repeat the measurement to verify that the phase matching at the entrance is correct.
  - (b) Measure and calculate the phase advance in the cell, defined from the center of the interspace region preceding the undulator to the center of the interspace region after the undulator. Add phase matching shims at the exit to give the cell phase its ideal value<sup>7</sup>.
12. Final checks
- (a) Check the x trajectory, y trajectory, and the phase at gaps from the minimum to the maximum operating gaps in 2 mm steps. Correct if necessary.
  - (b) Check the phase matching at the commissioning gap. Correct if necessary.
  - (c) With the long coil, check the first and second field integrals of  $B_x$  and  $B_y$  at gaps from the minimum to the maximum operating gaps in 2 mm steps. Correct if necessary.
  - (d) If corrections were done, repeat the checks.
  - (e) Check the gap with a clearance gauge to make sure no shim is protruding into the gap. Fix problems as necessary.
13. At this point, LBNL is done with their part of the tuning. The undulator should be sent to SLAC. At SLAC, step 12 will be repeated to verify that the undulator tuning did not change during transport. Small adjustments to the tuning may be made. Large adjustments require stopping to understand their source.

14. Final results data set

---

<sup>6</sup>Z. Wolf, "Phase Matching The LCLS-II Undulators", LCLS-TN-16-3, July, 2016.

<sup>7</sup>Ibid.

- (a) Verify the field integrals in the good field region. Use the long coil to measure the first and second field integrals of  $B_x$  and  $B_y$ . Measure from  $x = -1$  mm to  $x = +1$  mm in 0.5 mm steps with  $y = 0$ . Measure from  $y = -1$  mm to  $y = +1$  mm in 0.5 mm steps with  $x = 0$ . Repeat this at gaps from the minimum operating gap to the maximum operating gap in steps of 2 mm. Measure at  $x = 0, y = 0$  at gaps from the maximum operating gap to the maximum gap in steps of 10 mm. Place the data in the final results folder.
- (b) Make measurements to verify phase shake and to fit  $K$  and the phase matching settings. Perform Hall probe measurements at  $x = 0, y = 0$  mm at gaps from the minimum gap to the maximum operating gap in steps of 0.5 mm. Correct all Hall probe measurements to the first integral value measured with the long coil. Determine the  $K$  value at each gap setting. Verify that the fit to the  $K$  value vs gap measurements allows one to determine  $K$  at all gap settings to better than  $10^{-4}$  based on the residuals. Verify that the fit to the phase matching data allows one to determine the phase matching settings to better than 1 degree based on the residuals. The density of this data set may change based on measurements in the first few undulators. Verify that the phase shake is within tolerance at all measured gap settings. Place the data in the final results folder.
- (c) Place all undulator operating parameters, such as encoder offsets, in a file in the final results folder.

15. Add fiducialization magnets

- (a) Add the fiducialization magnets to the ends of the HXR undulator. The fiducialization magnets are permanently on the stands at the ends of the SXR undulator.
- (b) Measure the offset from the beam axis to the center of the fiducialization magnets.
- (c) Perform this measurement at both ends of the undulator.
- (d) For the SXR, have the alignment crew locate the tooling balls on the fiducialization magnets and on the undulator using a laser tracker. For the HXR, move the undulator to the CMM to locate the tooling balls on the fiducialization magnets relative to tooling balls on the undulator.

16. Fiducialization check

Perform a rough fiducialization check using manual alignment equipment. This is meant only to limit any possible errors.

17. Touch probe measurements

At gaps of 7.2 mm, 10 mm, 15 mm, and 20 mm as determined by the undulator gap encoders, perform touch probe measurements to record the mechanical gap at each pole. Put these results in the final results folder.

18. Additional HXR work

Add the interspace components and the vacuum chamber to the HXR undulator. Align the quadrupole to the undulator beam axis. Straighten the vacuum chamber

so that its center agrees with the undulator beam axis. Required alignment tolerances are given in the Physics Requirements Document<sup>8</sup>.

## 7 Measurement Results

All raw data and analysis results will be available from the SLAC web site. The data will be stored in a directory structure as show in figure 2. The top level directory is *Magdata*, followed by *LCLS-II*, followed by the magnet type *Undulator*. In the *Undulator* directory, there is a folder for each undulator named by the serial number. For each undulator, *Dataset* directories are made. When the undulator comes back for multiple measurements over time, each set of measurements goes into a new dataset. Within each dataset, the *Mechanical Measurements*, *Tuning*, *Fiducialization*, and *Final Results* folders are created. Each contains all the relevant measurements. For instance, the contents of the Tuning folder are shown in figure 3. Multiple runs are required and the data and analysis results from each run will go into a run folder. A list file will give a description of each run. Within a run, multiple measurements may be made. Each measurement and its analysis results will go in a folder whose name is determined by the measurement number, the gap, and the x and y probe positions for the measurement. The fixed width format is "nnnGapnnnpnnnXsnpnnYsnpnn", where "s" represents a sign, "p" represents a decimal point, and "n" is a digit used to give the measurement number, the gap in millimeters, or the probe position in millimeters. All data files will be text files. There will be several types of data files with different formats depending on the measurement. All Hall probe measurement data files will be called "bscanz.dat". All long coil or flip coil measurement data files will be called either "i1x.dat", "i2x.dat", "i1y.dat", or "i2y.dat" depending on the measurement. In this way the analysis programs can be more easily automated so the contents of a folder are known in advance. Analysis results will be in both text files and either postscript plot files or PDF plot files. A brief description of the types of files encountered in the various runs follows.

The mechanical measurements folder contains measurements from a touch probe or other device characterizing the mechanical properties of the undulator.

Capacitive sensor data will include a file containing the  $z$  position and all measured distances from the sensors. Another file will contain the calculated undulator pole position and orientation.

Align-x and Align-y data include files from scanning the Hall probe in x and y and finding the magnetic center. This is done at a number of poles down the undulator. Alternatively, scans at various  $x$  and  $y$  locations may be used.

The z-scan magnetic measurement data will consist of columns of the  $z$  positions, the  $V_x$  and  $V_y$  Hall probe voltages, and  $B_x$  and  $B_y$  values. Parameters, such as the Hall probe calibration file, will be included in a header. Two separate analysis programs will be run on the data. The first computes the trajectories, phase, etc. The second computes the shims required to tune the undulator. These programs output text files containing the results and also postscript or PDF files containing plots.

---

<sup>8</sup>H. D. Nuhn et al., "Undulator System Requirements", LCLS-II Physics Requirements Document LCLSII-3.2-PR-0038-R2.

The long coil data will consist of the  $(x, y)$  location of the coil, parameters of the coil motion, the integrated voltage, and the first and second field integrals. Multiple measurements will be done. Each measurement will be recorded and the average and rms deviation will be provided. Output files will be text files containing a header and the first and second integrals of  $B_x$  and  $B_y$ .

When long coil or flip coil measurements are associated with a particular Hall probe scan in order to correct Hall probe offsets, the coil data may be placed in the folder with the associated Hall probe measurement.

After the tuning runs are complete, a special set of final measurement runs is made. The analysis results from these runs will go into a Final Results folder. The contents of the Final Results folder are shown in figure 4.

The fiducialization data will be put in its own folder. The data comes from several sources: scale readings from the measurement bench, offsets between the center of the fiducialization magnets and tooling balls, laser tracker data, and alignment crew data. All files will be text files containing a header and the measured values. A program will read the data and write a fiducialization report containing the final results.

## 8 Summary

SLAC and LBNL will together perform the LCLS-II undulator tuning and magnetic measurements. SLAC will use two measurement benches and LBNL will use one. SXR undulators will all be tuned, have final data sets measured, and fiducialized at one of the SLAC benches. HXR undulators will be worked on by both LBNL and SLAC, with SLAC performing all final data sets and fiducialization. The Earth's field will be properly taken into account by tuning undulators in the same orientation they will have in the tunnel, performing Helmholtz coil measurements, and by a set of measurements in the tunnel which will determine small corrections to the laboratory measurements. A calibration will be performed to determine the temperature dependence of  $K$ . A transportation test to the tunnel will also be performed.

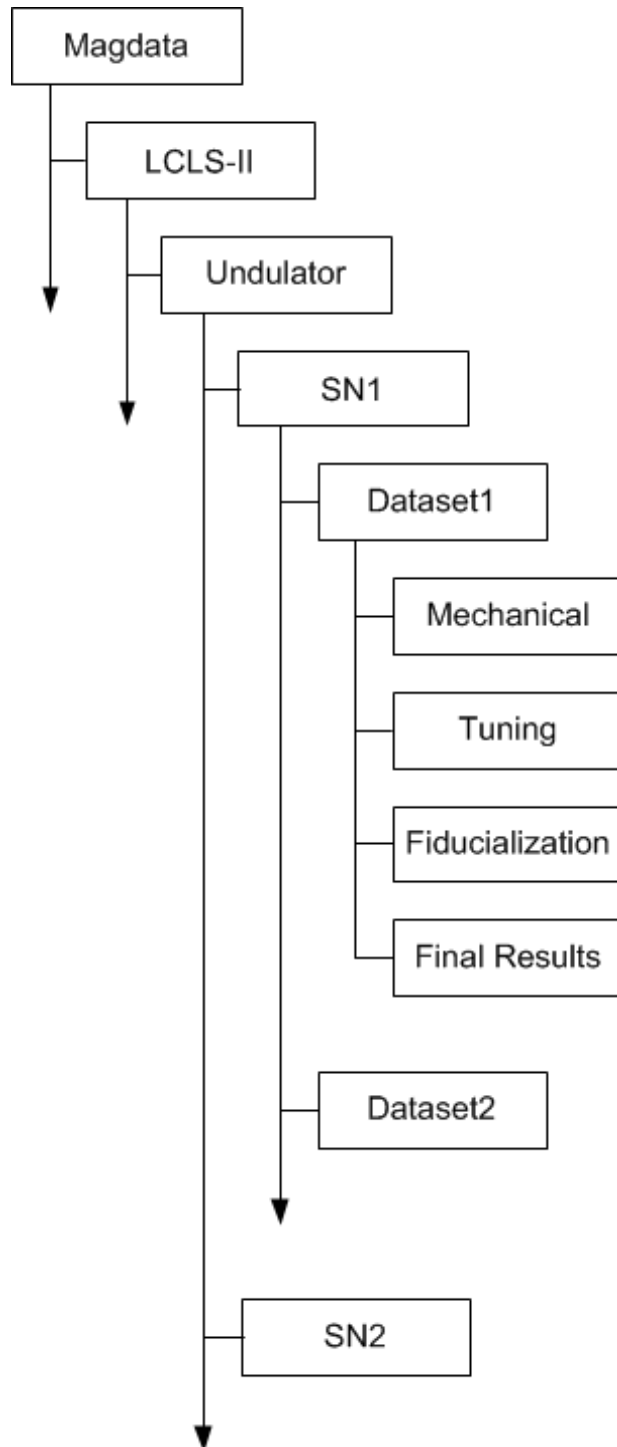

Figure 2: The undulator measurement data will be stored in a directory structure.

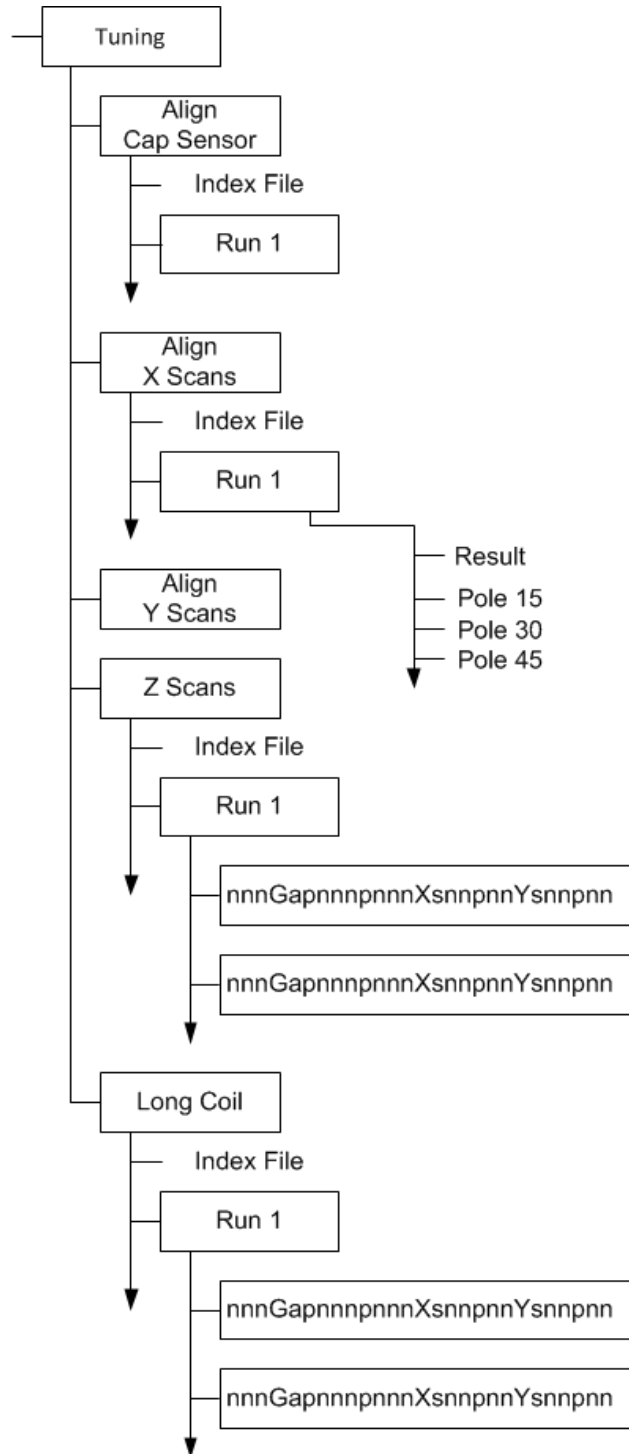

Figure 3: Contents of the Tuning folder.

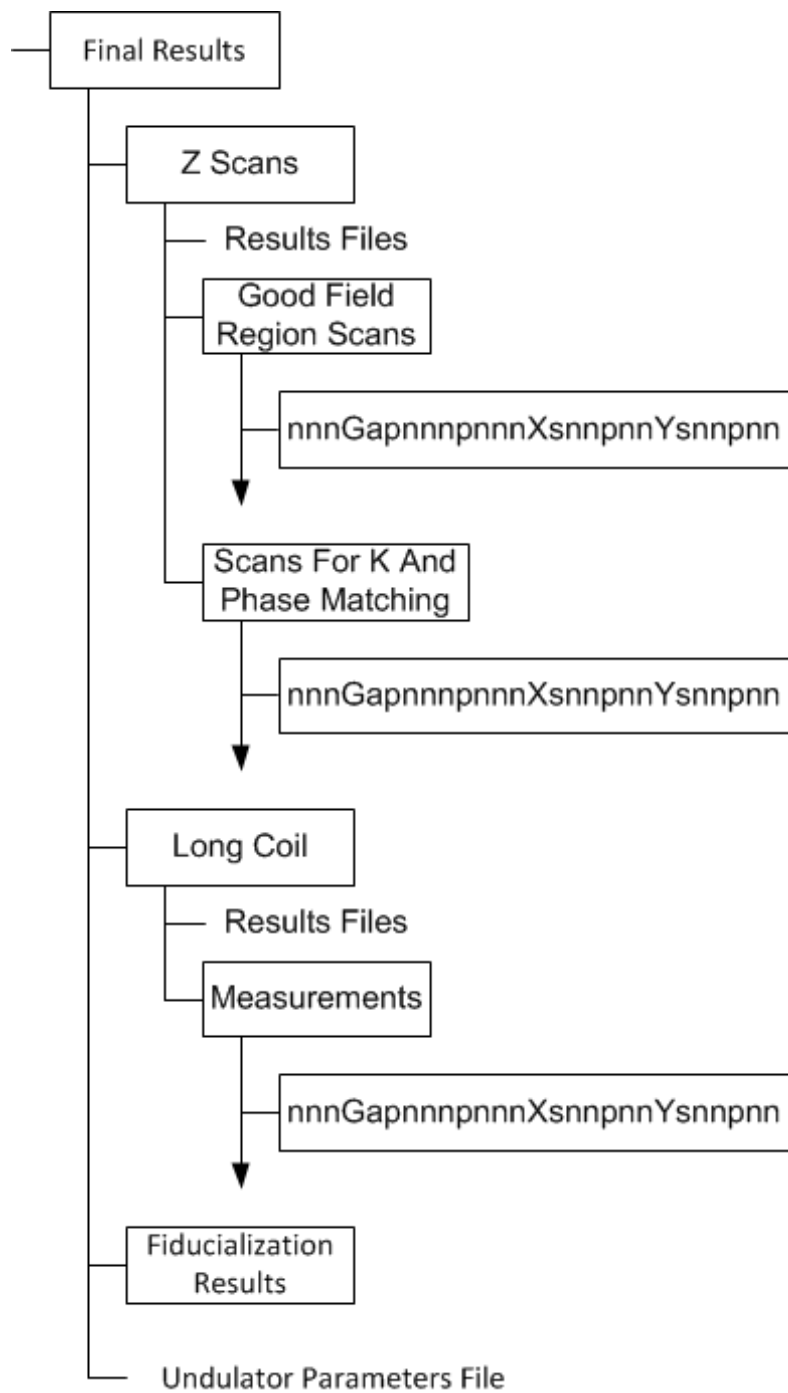

Figure 4: Contents of the Final Results folder.