

NON-COMPLIANCE REPORT # 31791-79

PART NAME: WINDOW FLANGE, 15mm ID
 PF/SA NO.: PF-391-440-05 R0
 WORK ORDER NO.: 31791-79
 VENDOR: KLY MACH SHOP

DATE: 7/7/15
 INSPECTOR: K. CABAN
 ENGINEER: JC EXT.: 5109
 PLANNER: DIANNA T.

Reason for Non-Compliance:

1. $\varnothing .799 \pm .005$ fits only a 0.7938 gage pin, .7942 does not fit.
2. Flange Knife Edge Detail is NOT machined
 - a. $2X R .012 \pm .005$ measures .0014
 - b. $75^\circ \pm .5^\circ$ is not machined measuring 89.1227°

Disposition (UAI, Rework, Scrap, Other):

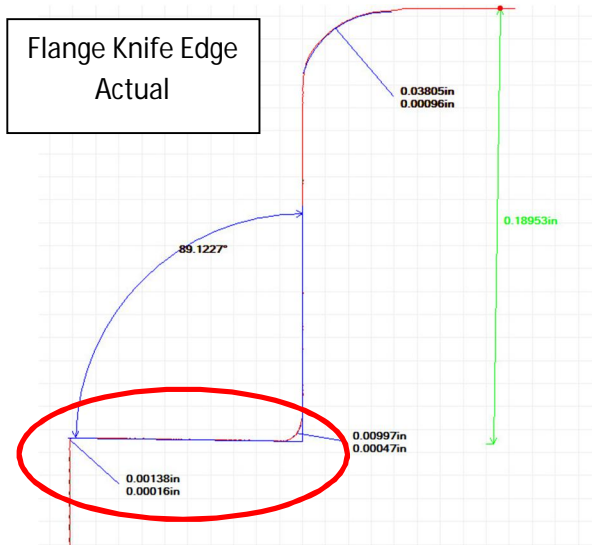
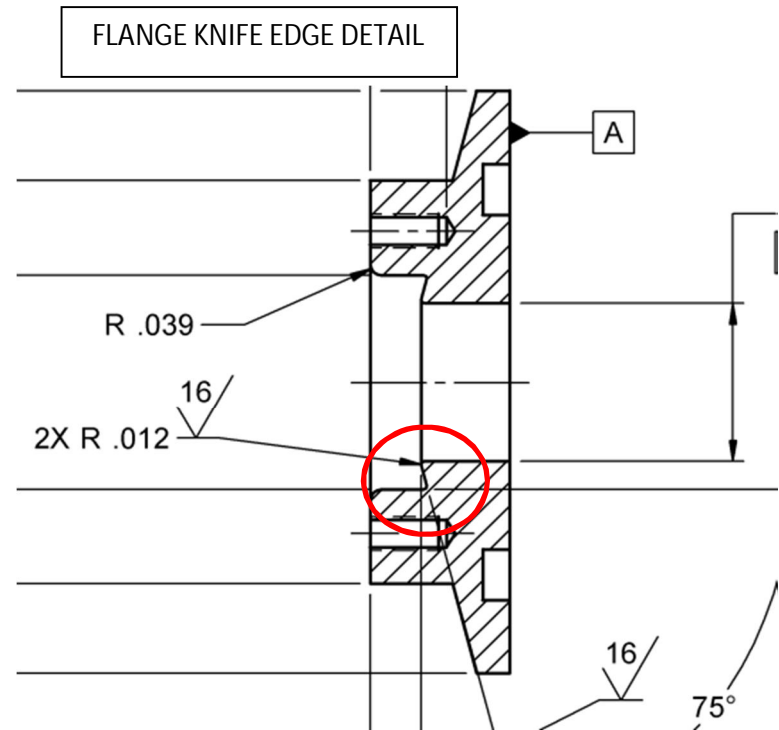

Engineer Signature: _____

Date: _____