

NONCONFORMANCE REPORT (NCR)

SUBSYSTEM MFD 28932-15	DESCRIPTION OF ITEM BASE	DATE 11/16/12
ORIGINATOR K. Caban	PART NO. & REV. PF-380-805-01 R2	SERIAL NO.(s) 101

NONCONFORMANCE DESCRIPTION

Nonconformance Description (Describe the nonconformance; ensure the applicable requirements, planned activities, procedures, specifications, drawing, standards, serial numbers, etc. are noted. Indicate who documented the nonconformance.)

1. Parallelism .0002 of distance .2299 to Datum –A- measures 0.00022 (+0.00002” out of parallel).
2. Distance 1.3390 ± 0.0002 measures 1.33958 (+0.00038” out of tolerance).
3. Parallelism .0002 of distance 1.3390 to Datum –A- 0.00021 (+0.00001” out of parallel).
4. 2X Distance .9522 +0.0002/-0.0000 measures 0.95179 (-0.00041” out of tolerance).
5. 2X Position of 0.0002 of 2X R 1.4119 measures 0.00091 (+0.00071” out of position).
6. Distance 2X 3.087 ± 0.001 measures 3.08470 (-0.00130” out of tolerance).
7. Distance 2X 3.538 ± 0.001 measures 3.53569 (-0.00131” out of tolerance).
8. Iris diameter $1.0319 +0.0002/-0.0000$ measures 1.03161 (-0.00029” out of tolerance).
9. Position of 0.0002 of Iris diameter 1.0319 measures 0.00032 (+0.00012” out of position).
10. Profile 0.0002 X-Y is out of surface profile (see attached profile plot, also has plots of cavity and cover-lid where near top of the part, where top of cavity and lid profiles “spring” inward, bottom of cavity is okay).
11. R. $.012 \pm 0.001$ measures 0.0172 (+0.0042” out of tolerance).

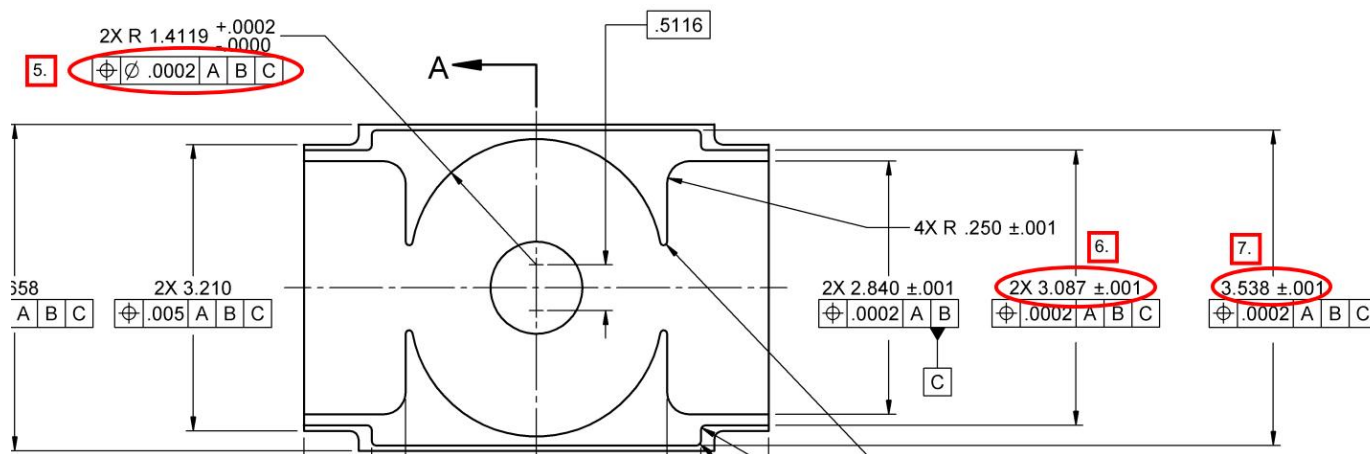

See next page for more info...

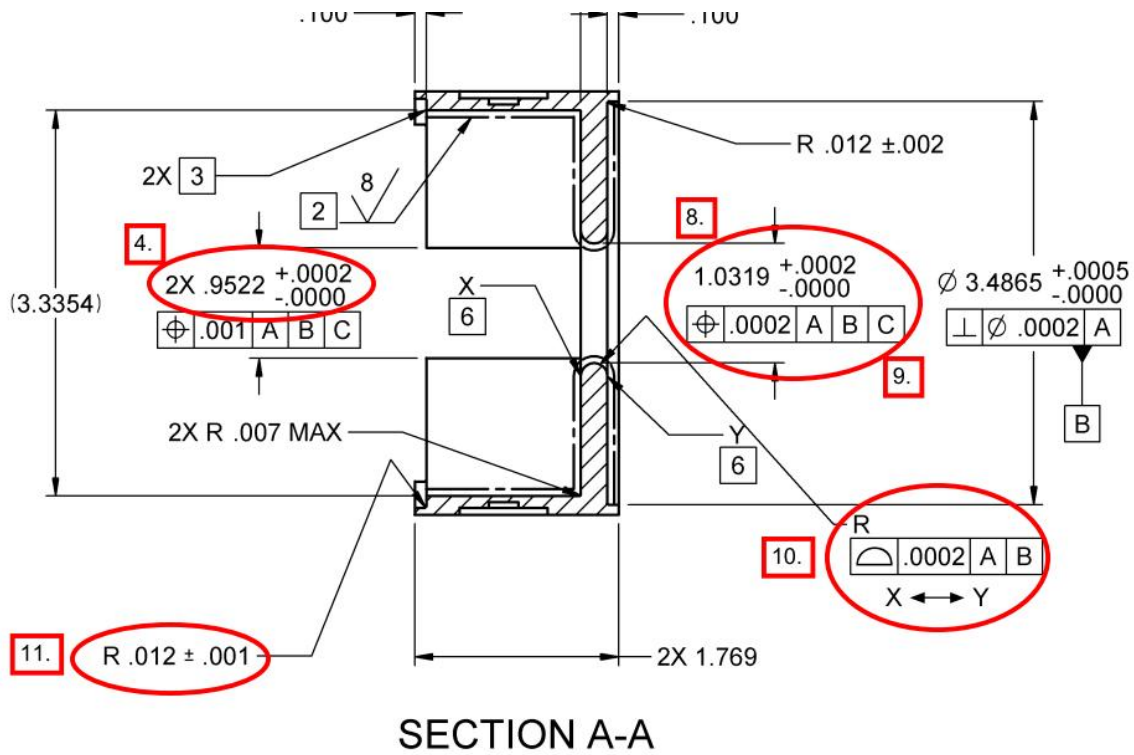

DISPOSITION

Disposition: (Describe for each cause what action(s) will be taken with the item or process, including, as applicable, the completion dates, disposition of material, and responsible staff for each action. The completion dates, disposition of material, and responsible staff for each action.

CORRECTIVE/PREVENTIVE ACTION | ASSIGNED TO:

Corrective/Preventive Action: Describe, as applicable, what actions are needed to prevent recurrence of the identified nonconformance, such as process improvement, procedure revisions, training plan, etc., and include completion dates and responsible staff for each action.)

FOLLOW-UP REQUIRED: ρ Yes ρ No

NCR CLOSEOUT APPROVALS

LCLS-II TECHNICAL REPRESENTATIVE	DATE	LCLS-II QUALITY ASSURANCE	DATE
----------------------------------	------	---------------------------	------

FOLLOW UP EFFECTIVE ρ Yes ρ No	FOLLOW UP BY:	DATE
-----------------------------------	---------------	------