



MFD NON-COMPLIANCE REPORT # 29282-8

PART NAME: **RETR SAMPLE HOLDER**
PF/SA NO.: **PF-380-541-52 R0**
WORK ORDER NO.: **29282-8 (7723208)**
VENDOR: **MFD**

DATE: **10/25/12**
INSPECTOR: **K. CABAN**
ENGINEER: **E. KRAFT** EXT.: **2061**
ROUTE TO: **MTLFNSH**

Reason For Non-Compliance:

Action (UAI,RWK,SCRIP)

1. $\text{C} \text{ .001 A B C}$ exceeds the ± 0.0005 " tolerance band on the entire surface, primarily at the 2X R .062 by 0.009 on both parts. (See attach profile plots)

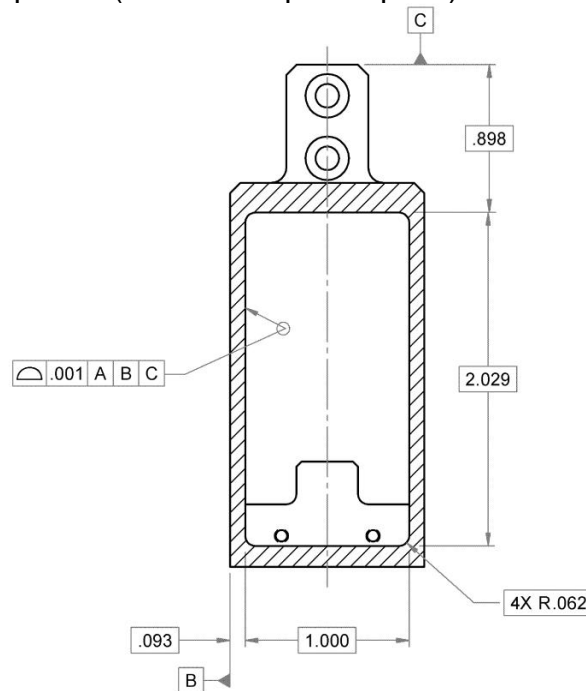

Engineer Signature: _____ Date: _____



INSIDE PROFILE

TOLERANCE (mm)
+0.0127
-0.0127

± 0.0005"

Hexagon PTS
Walter-Zapp-Str. 4
35578 Wetzlar
Tel. +49 6441 2109 0
www.Quindos.de

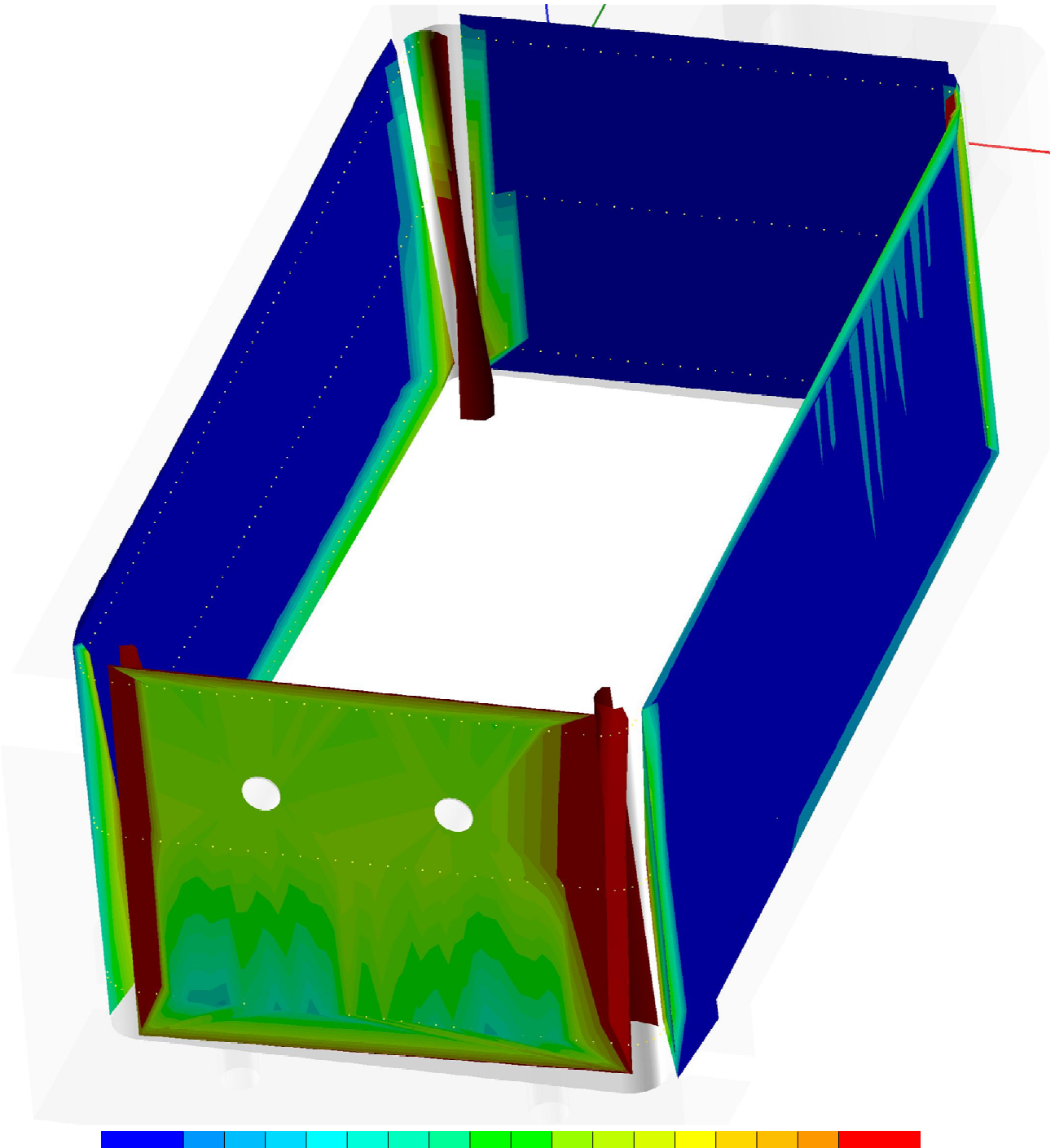

-0.013

0

0.013

Element :	Minium deviation					Maximum deviation				
	No.	Dev.	- X -	- Y -	- Z -	No.	Dev	- X -	- Y -	- Z -
ACNO\$ALL	446	-0.06842	17.04369	-22.80920	18.79600	131	0.24846	27.01022	-74.10814	2.54000

Description	: RETR SAMPLE HOLDER	Order	: 29282-8 (7723208)
Customer	: E. KRAFT	Department	: MET. QUALITY INSPECTION
Drawing number	: PF-380-541-52	Inspector	: kcaban
Serial number	: 101	Inspection date	: 25-OCT-2012-08:47:09
Remarks	:	QDS-Version	: Quindos7 - V 7.6.12222
Article number	:	Measuring device	: PMM 12 10 6 #581



INSIDE PROFILE

TOLERANCE (mm)
+0.0127
-0.0127

± 0.0005"

Hexagon PTS
Walter-Zapp-Str. 4
35578 Wetzlar
Tel. +49 6441 2109 0
www.Quindos.de

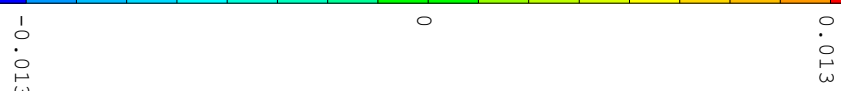
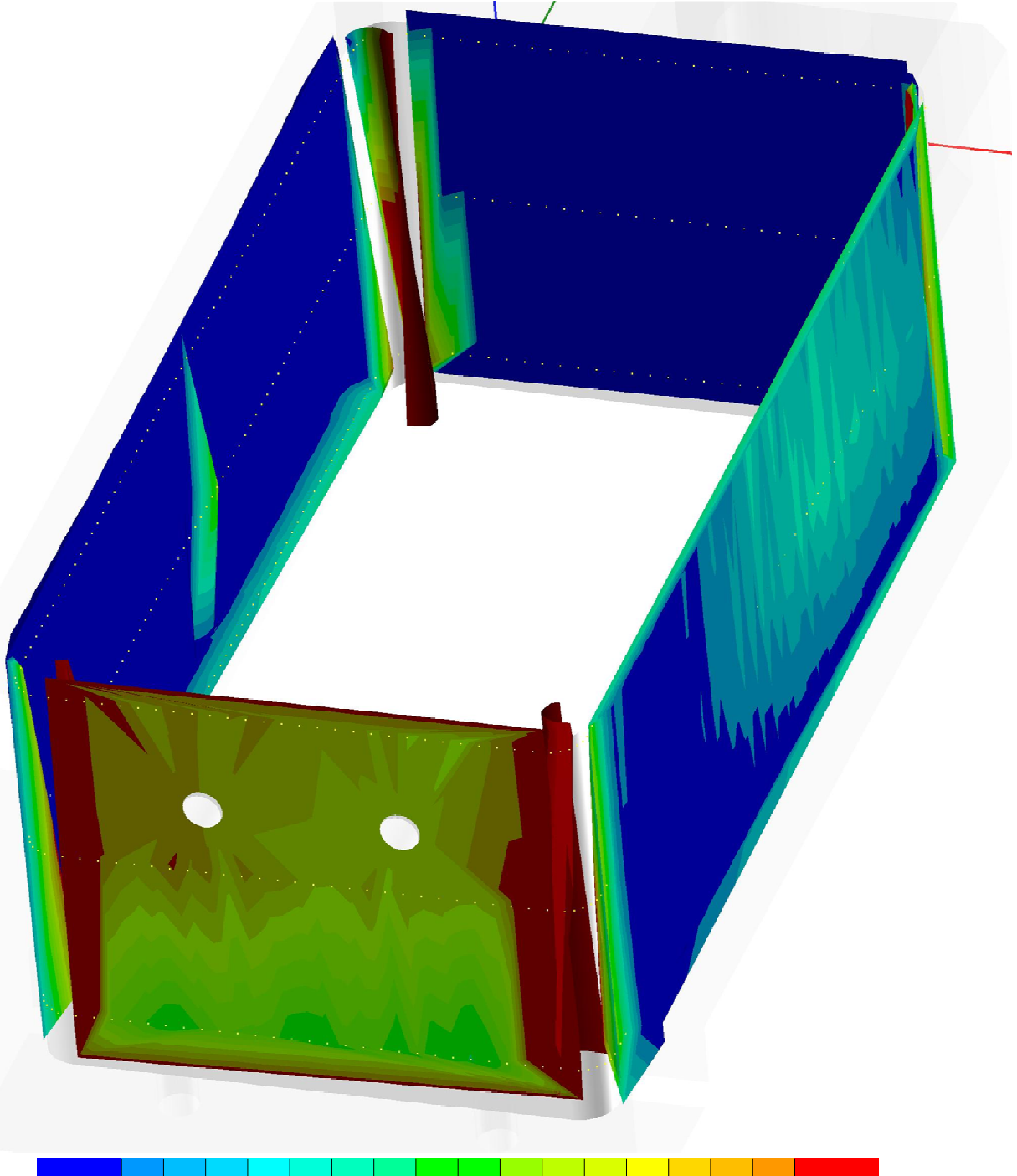

Element :	Minium deviation					Maximum deviation				
	No.	Dev.	- X -	- Y -	- Z -	No.	Dev.	- X -	- Y -	- Z -
ACNO\$ALL	198	-0.06820	2.36220	-46.75757	2.54000	131	0.22631	27.01022	-74.10814	2.54000

Description	: RETR SAMPLE HOLDER	Order	: 29282-8 (7723208)
Customer	: E. KRAFT	Department	: MET. QUALITY INSPECTION
Drawing number	: PF-380-541-52	Inspector	: kcaban
Serial number	: 102	Inspection date	: 25-OCT-2012-09:56:01
Remarks	:	QDS-Version	: Quindos7 - V 7.6.12222
Article number	:	Measuring device	: PMM 12 10 6 #581