

SLAC Traveler for LCLS Everson-Tesla Quadrupole Magnets

This traveler is intended to cover reception, preparation, mechanical fiducialization, and magnetic measurements of the Everson Tesla quadrupole magnets. Thirty of these magnets were ordered, 12 for the injector, 7 for the linac, 7 for the LTU, and four are spares.

Receiving:

The following information is to be noted upon receipt of the magnets by the SLAC MFD group:

| | | |
|---|-----------------|--|
| Received by | S. RYAN | name |
| Date received | 4/3/06 | mm/dd/yy |
| SLAC barcode number: | | #000390 |
| SLAC drawing number: | SA-380-309-00r0 | |
| Vendor serial number from magnet label: | | # 006 |
| SLAC approved electrical safety covers? | | <input checked="" type="checkbox"/> Y <input type="checkbox"/> N |
| SLAC approved lifting eyes? | | <input checked="" type="checkbox"/> Y <input type="checkbox"/> N |
| Shipping Damage? | | <input checked="" type="checkbox"/> Y <input type="checkbox"/> N |
| Vendor tests passed on magnet label? | | <input checked="" type="checkbox"/> Y <input type="checkbox"/> N |

| | |
|---------------------------------------|--|
| Place Duplicate BarCode Sticker Here: |  |
|---------------------------------------|--|

Preparation:

The following tasks are to be undertaken by the SLAC MFD group to prepare the magnets:

- 1) The mirror plates and standoffs are to be removed from these magnets. Please store these mirror plates and standoffs, and do not discard.

| | | |
|-----------------------|-----------|-----------------|
| Mirror plates removed | E. CASTRO | technician name |
|-----------------------|-----------|-----------------|

- 2) A beam direction arrow, with text "beam direction", is to be affixed to the top and connector side of the magnet, preferably by stenciling or rubber stamp, or by

sticker supplied by LCLS The arrow is to point away from the face of the magnet that has the coil bus wires. The coil bus wires are thus on the upstream side of the magnet. The positive and negative power leads are to be marked with '+' and '-' stickers, as shown in the wiring diagram.

3) A 14 gauge multistrand wire with red, non-teflon insulation is to be prepared with spade lugs and installed as shown in the wiring diagram below:

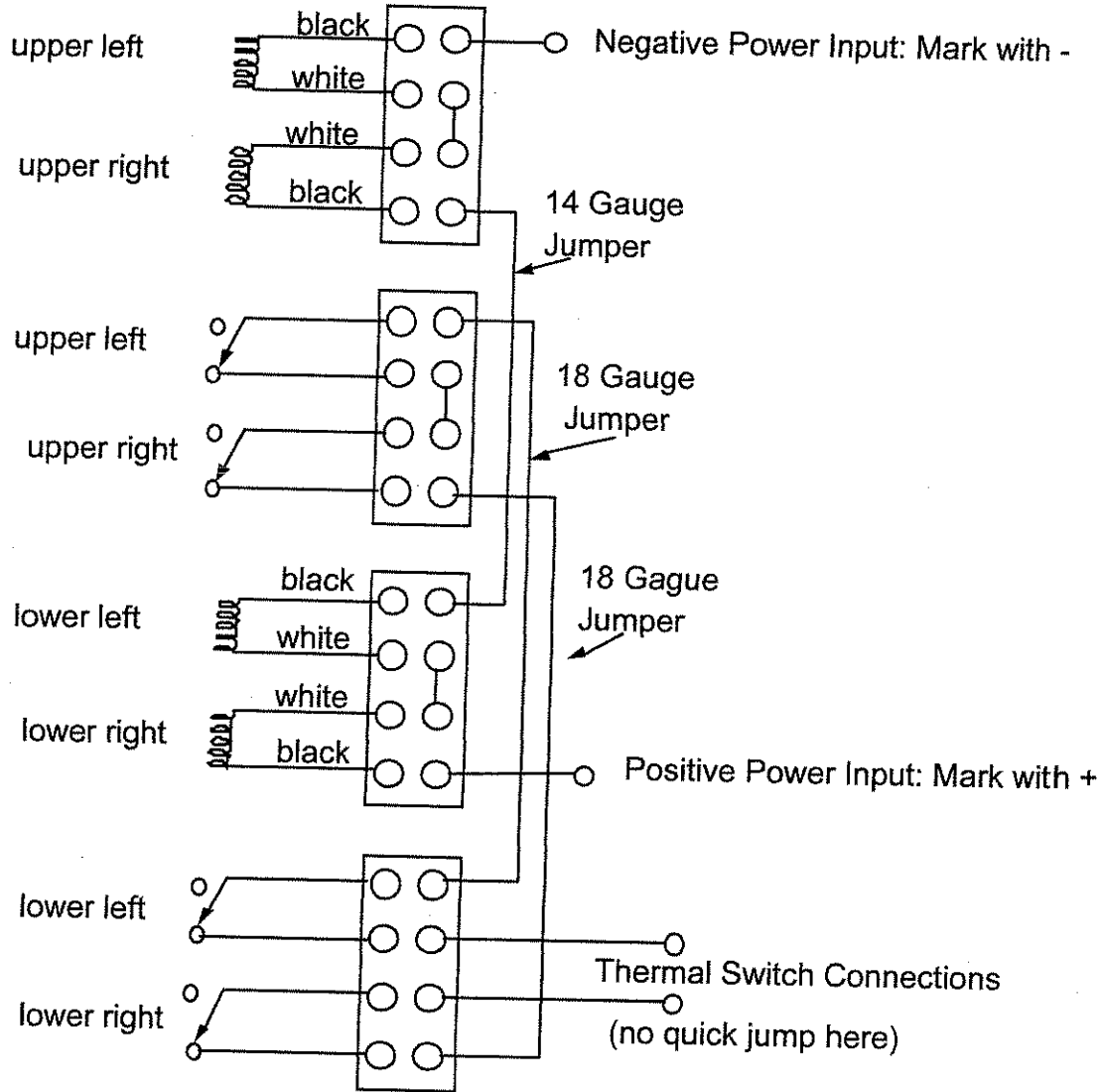

left and right refer to observer looking downstream, in the beam direction

| | | |
|---------------------------|---------|----------------|
| 14 Gauge Jumper installed | S. RYAN | installer name |
|---------------------------|---------|----------------|

4) Two 18 gauge multistrand wire jumpers with non-teflon insulation are to be prepared with spade lugs and installed as shown in the wiring diagram above.

| | | |
|----------------------------|---------|----------------|
| 18 Gauge Jumpers installed | S. RYAN | installer name |
|----------------------------|---------|----------------|

5) The main magnet coil power leads must be connected according to the color scheme indicated in the wiring diagram, which is different from the way the magnets are as delivered. A terminal block type jumper is to be installed to connect the two white leads together.

| | | |
|---|---------|----------------|
| main power leads connected correctly, with jumper | S. RYAN | installer name |
|---|---------|----------------|

6) The magnet is to be mounted a T-1 stage, oriented according to the correct beam direction, as shown in the photo:

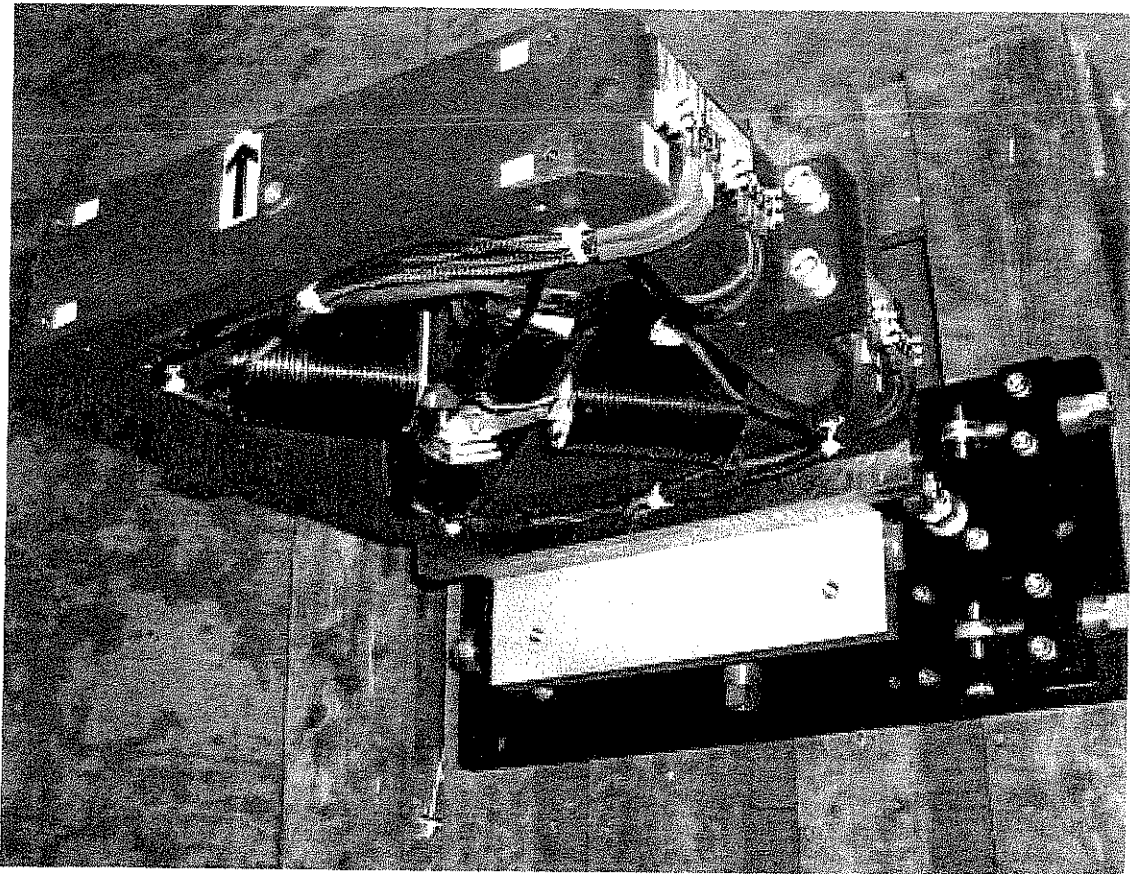

This requirement is for the first 15 magnets; the next 9 may be mounted on various stages.

| | | |
|---------------------|---------|----------------|
| T-1 Stage Installed | S. RYAN | installer name |
|---------------------|---------|----------------|

Fiducialization:

Fiducialization may be done before or after magnetic measurements. The magnet is to be fiducialized by the CMM group. This will require the installation of removable tooling balls, location of the geometric axis of the pole tips of the magnet, and location of tooling balls with respect to the center of this geometric axis when the poles are aligned precisely at ± 45 degrees to horizontal and vertical axes. A CMM fiducialization report should be attached to this traveler.

| | | | |
|-----------------|----------|----------|-----------------|
| Report attached | V. CABAN | 06/01/06 | Technician name |
|-----------------|----------|----------|-----------------|

URL of on-line CMM fiducialization data:

\\Web002\www-group\met\Quality\FIDUCIAL REPORTS\LCLS QUADS\LCLS QUAD 000390.pdf

Magnetic Measurements:

Upon receipt of the magnet, the following information should be recorded:

| | | |
|--|----------|----------|
| Date of arrival to Mag. Meas. group: | 06/15/06 | mm/dd/yy |
| Responsible measurement operator name: | SDJ | name |

The magnetic measurements group is requested to perform the following tasks:

- 1) Verify that the magnets have mirror plates removed, jumpers correctly installed, main coil wiring corrected if necessary, and beam direction arrows put on. Also inspect magnet for any visible flaws and damage.

| | | |
|------------------------|-----|-----------------|
| Incoming inspection OK | SDJ | technician name |
|------------------------|-----|-----------------|

2) Connect the magnet to a bipolar 12-A power supply, preferably an *MCOR12*. Use care in turning these supplies on and off to limit current spikes that may occur. Run the magnet up to 8 A for ~30 minutes to warm it up (record temperature).

| | | |
|--------------------------------|---------|--------------------|
| Power supply type | MCOR 12 | text |
| Magnet connected and warmed up | SDA | technician name |
| Magnet temperature achieved | 26.1 | deg A C |

3) Standardize the magnet, starting from 0 to +12 A, then through 3 full cycles from +12 A to -12 A and back up to +12 A, finally ending at -12 A (the *MCOR12* ramp rate is not controllable, but a flat-top pause time of 10 seconds is desired at each maximum and minimum current).

| | | |
|---------------------|-----|-----------------|
| Magnet standardized | SDA | technician name |
| | | |

In the following measurements, place the data in an on-line file folder:

URL of on-line magnet measurement data:

Record the following information about the rotating coil:

| | | |
|---------------------------|----------|--------|
| Rotating Coil Designation | DC 2-54 | name |
| Rotating coil radius | 0.012313 | meters |

4) Maintaining the history cycle, measure length integrated $\int Gdl$ with a calibrated rotating coil, from -12 A to +12 A in 1-A steps, including zero (25 'up' measurements).

| | | |
|-----------------------------------|------------|------------|
| $\int Gdl$ data file name & run # | strdat.ru1 | name and # |
|-----------------------------------|------------|------------|

5) Still maintaining the history cycle, measure $\int Gdl$ with a calibrated rotating coil back down from +12 A to -12 A in 1-A steps, including zero (25 'down' measurements).

| | | |
|----------------------------|------------|------------|
| Gdl data file name & run # | str.dat.ru | name and # |
|----------------------------|------------|------------|

6) Measure field harmonics at -12, -6, +1, +6, and +12 A settings using a 1-inch or 0.8-inch diameter probe.

| | | |
|---------------------------------|------------|------------|
| Harmonic data file name & run # | harded.ru2 | name and # |
|---------------------------------|------------|------------|

7) Measure the inductance and resistance of the full magnet

| | | |
|---------------------------|-------|-------------|
| Inductance of full magnet | 21.5 | mH @ 100 Hz |
| Resistance of full magnet | 0.392 | Ohm |

| | | |
|-----------------------------------|------------|------------|
| Date of completion of SLAC tests: | 06/15/2006 | mm/dd/yyyy |
|-----------------------------------|------------|------------|

Upon completion of tests, send traveler to Paul Emma, ms 103

8) Approval and Assignment by Paul Emma:

| | | |
|-------------------|------------------|---|
| Magnet accepted: | <i>Paul Emma</i> | <input checked="" type="checkbox"/> Y/N |
| Assigned Location | QM12 | Mad Deck Name |

Upon completion, send traveler to Kathleen Ratcliffe at mailstop 18

Reference Information:

In a 24 hour measurement of the first article of this magnet type at 10 Amps, the temperature was found to rise to 31C over an ambient of 20C. See <http://www-group.slac.stanford.edu/met/MagMeas/MAGDATA/LCLS/quad/QM-001/>.

In a 36 hour test by Achim Wiedemann at 15.5 Amps, the temperature was found to rise to about 45 C from an ambient of 20C.

The magnet polarity is shown in the schematic diagram below:

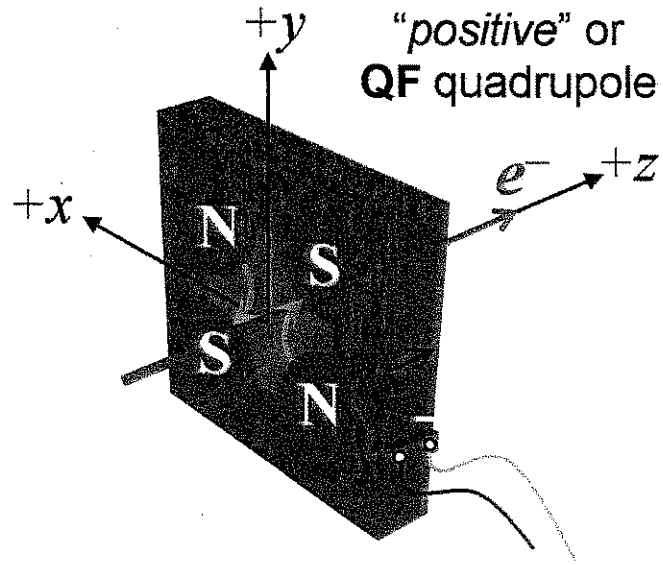

ET Quadrupole without Mirror-Plates (measured June 15, 2006)

Current VS GdL: ET-quad 000390

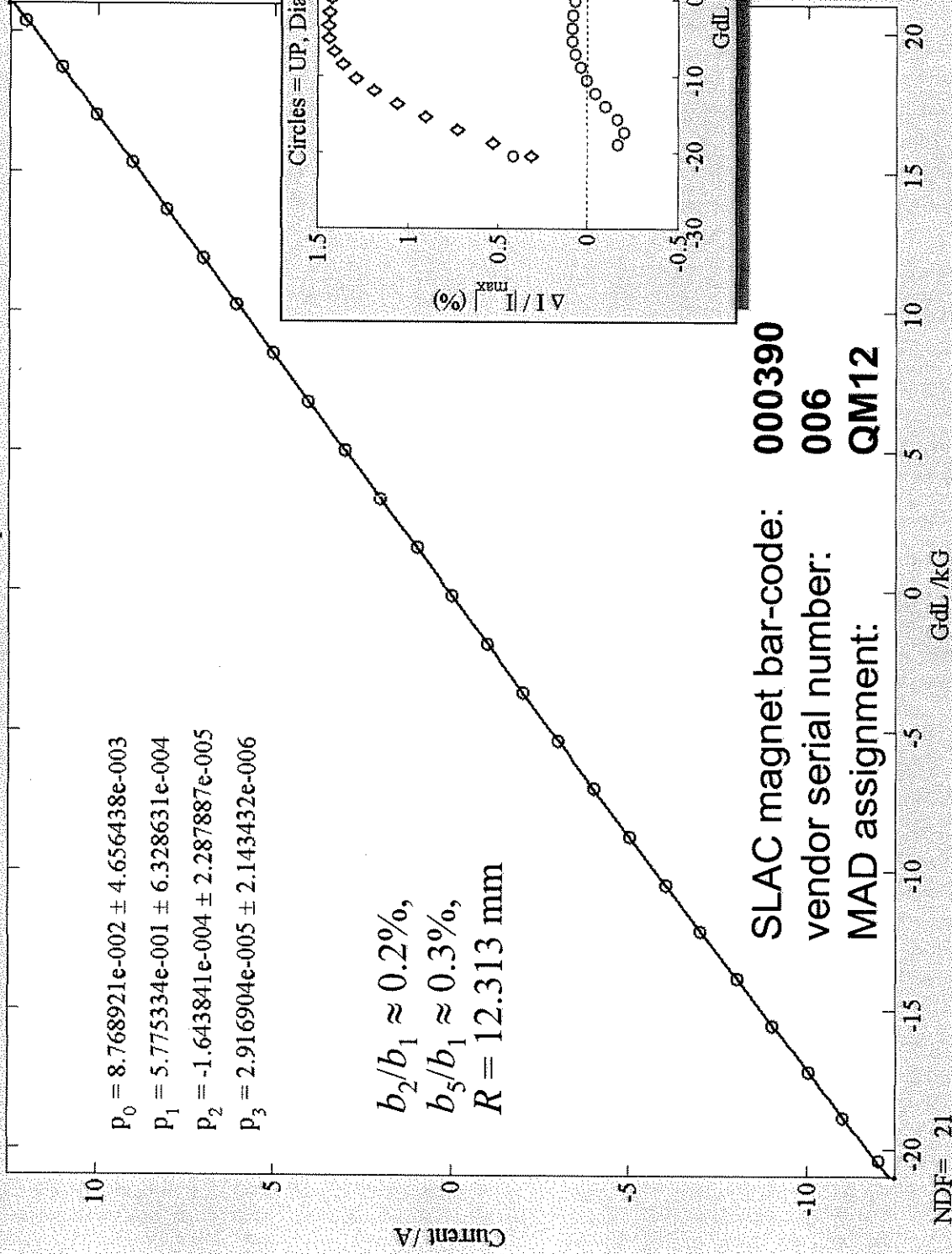

$$P_0 = 8.768921e-002 \pm 4.656438e-003$$

$$P_1 = 5.775334e-001 \pm 6.328631e-004$$

$$P_2 = -1.643841e-004 \pm 2.287887e-005$$

$$P_3 = 2.916904e-005 \pm 2.143432e-006$$

$$b_2/b_1 \approx 0.2\%$$

$$b_5/b_1 \approx 0.3\%$$

$$R = 12.313 \text{ mm}$$

SLAC magnet bar-code: 000390

vendor serial number: 006

MAD assignment: QM12

NDF= 21

RMS=0.0141 A