

NONCONFORMANCE REPORT (NCR)

SUBSYSTEM MFD 28932-26	DESCRIPTION OF ITEM CUP 2	DATE 11/5/12
ORIGINATOR K. Caban	PART NO. & REV. PF-380-805-19 R2	SERIAL NO.(s) 101

NONCONFORMANCE DESCRIPTION

Nonconformance Description (Describe the nonconformance; ensure the applicable requirements, planned activities, procedures, specifications, drawing, standards, serial numbers, etc. are noted. Indicate who documented the nonconformance.)

1. Diameter $3.2826 +0.0002/-0.0000$ measures $3.28221 (-0.00039''$ undersized).
2. Diameter $3.4865 +0.0005/-0.0000$ measures $3.48613 (-0.00037''$ undersized).
3. Surface Profile 0.0002 X-Y is out of tolerance. See attached iris profile plot.

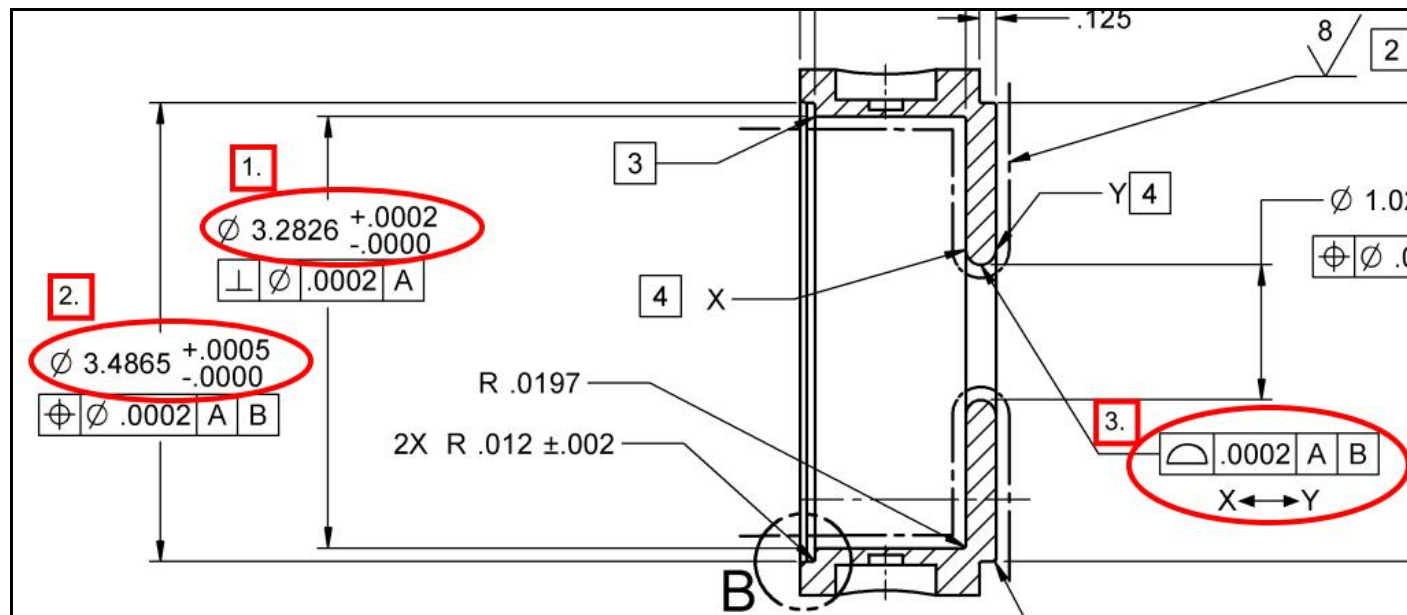

DISPOSITION

Disposition: (Describe for each cause what action(s) will be taken with the item or process, including, as applicable, the completion dates, disposition of material, and responsible staff for each action. The completion dates, disposition of material, and responsible staff for each action.)

CORRECTIVE/PREVENTIVE ACTION

| ASSIGNED TO:

Corrective/Preventive Action: Describe, as applicable, what actions are needed to prevent recurrence of the identified nonconformance, such as process improvement, procedure revisions, training plan, etc., and include completion dates and responsible staff for each action.)

FOLLOW-UP REQUIRED: ρ Yes ρ No

NCR CLOSEOUT APPROVALS

LCLS-II TECHNICAL REPRESENTATIVE

DATE

LCLS-II QUALITY ASSURANCE

DATE

FOLLOW UP EFFECTIVE
ρ Yes ρ No

FOLLOW UP BY:

DATE

XZ PLANE

DEVIATIONS @ 180°:

MIN: -0.00025
MAX: 0.00015
TOL: +/- 0.0001

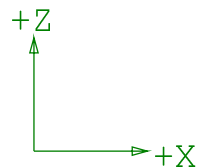
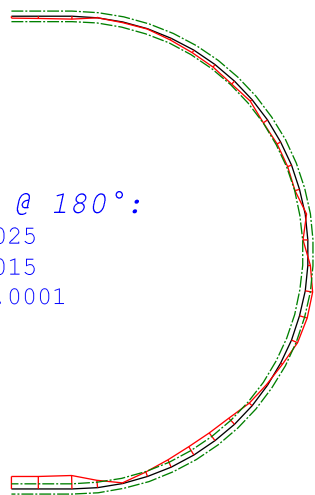

DEVIATIONS @ 0°:

MIN: -0.00022
MAX: 0.00014
TOL: +/- 0.0001

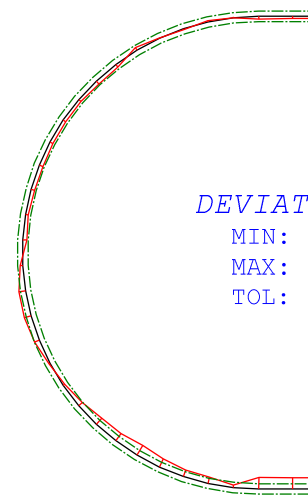

IRIS 2D-XZ DIST.: 1.02735

YZ PLANE

DEVIATIONS @ 270°:

MIN: -0.00023
MAX: 0.00010
TOL: +/- 0.0001

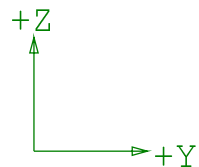
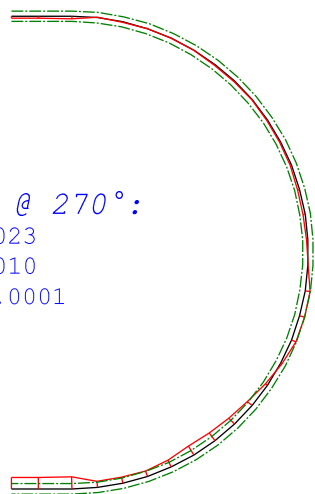

DEVIATIONS @ 90°:

MIN: -0.00025
MAX: 0.00007
TOL: +/- 0.0001

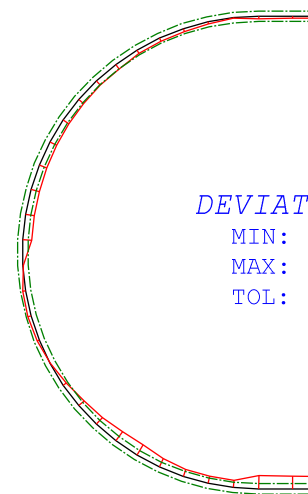

IRIS 2D-YZ DIST.: 1.02743



IRIS PROFILE
DRAWING NO.: PF-380-805-19 R2
SERIAL NO.: 101

BLACK = NOMINIAL
RED = ACT-NOM CRV
GREEN = TOLERANCE
INSP.: kcaban
01-NOV-2012