

# HIGH PRECISION ALIGNMENT FOR THE HISTAR PROJECT

Hubert Dupraz, Institut de Géomatique, Ecole Polytechnique Fédérale, Lausanne, [hubert.dupraz@epfl.ch](mailto:hubert.dupraz@epfl.ch)

Williame Coosemans, CERN, Métrologie de positionnement, Genève, [williame.coosemans@cern.ch](mailto:williame.coosemans@cern.ch)

Frédéric Ossart, Société FOGALE Nanotech, Nîmes, [info@fogale.fr](mailto:info@fogale.fr)

Vincent Bourquin, Institut de Machines Hydrauliques et de Mécanique des Fluides, Ecole Polytechnique Fédérale, Lausanne, [vincent.bourquin@epfl.ch](mailto:vincent.bourquin@epfl.ch)

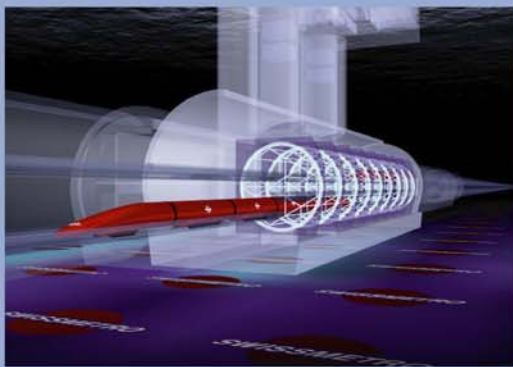

## SWISSMETRO

The Swissmetro SA company has the goal to develop a new and revolutionary high-speed transport system, able to carry passengers in full safety at speeds exceeding 400 and even 500 km/h. This transport system, called Swissmetro, consists in an underground Maglev travelling through a tunnel network of small diameter in which, to diminish the energetic consumption, the air pressure is reduced to approximately 10% of the atmospheric value. The Swissmetro system is presently under design by using several numerical and experimental simulations, and the operational start up of a first pilot line could occur before 2015.

## (acronym for High-Speed Train Aerodynamic Rig) HISTAR

HISTAR project is a reduced-scale rig under construction in Lausanne with the purpose to analyse the aerodynamic effects generated by the high-speed transport systems in general and the SWISSMETRO system in particular. The HISTAR rig is basically a 250-meter long track on which a vehicle model at scale 1/10 will be towed at speeds over 500 km/h by two high performance hydraulic units, the power of which exceeds 1.2 MW.

When the vehicle is in motion, additional transverse loads appear as the vehicle follows the non-straight trajectory due to the differences between the track guiding surfaces and ideal straight planes. The minimal requirements for the allowed difference between the track geometry and an ideal straight line are 1 mm over 7 m, 0.1 mm over 2 m and 0.02 mm over 1 m.

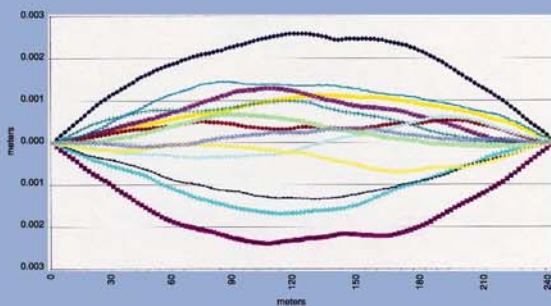
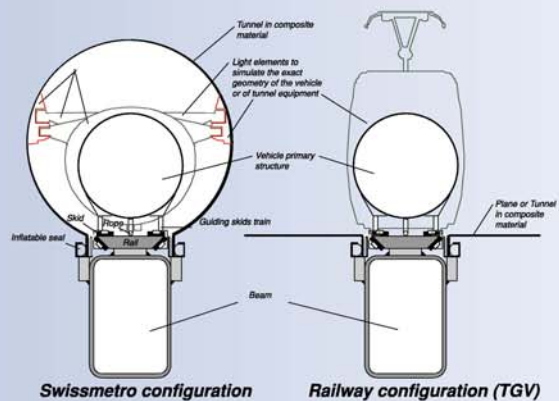

## Why a high precision alignment?

When the vehicle is in motion, additional transverse loads appear as the vehicle follows the non-straight trajectory due to the differences between the track guiding surfaces and ideal straight planes. The minimal requirements for the allowed difference between the track geometry and an ideal straight line are 1 mm over 7 m, 0.1 mm over 2 m and 0.02 mm over 1 m. More than hundred sets of observations have been simulated. Each set corresponds to a 240m long setup surveyed by a train that has four ecartometers (non-contact position sensors). The standard deviation of an individual measurement is 0.01mm per sensor. The adjustment of the simulated measurements shows that the resulting trajectories are smooth and stay all within the 3mm wide envelope around the theoretical alignment defined by the two marginal points. In addition, the figure shows 11 trajectories chosen at random.

## The concept of the support system

Variations of the “Six Strut” support system are used on hundreds of position sensitive components in the ALS accelerator, storage ring and beamlines. The basic idea is simple: The position of a rigid body in space has six degrees of freedom; -X , Y , Z ; and angular: -pitch, roll, and yaw. A support system which uses six orthogonal links, or struts, provides “kinematic” support, that is, just enough support with no additional constraints which could stress and distort the body itself. The struts have ball jointed end connections, and are arranged orthogonally to simplify position adjustments.

(according to W.Thur and al., 1997)

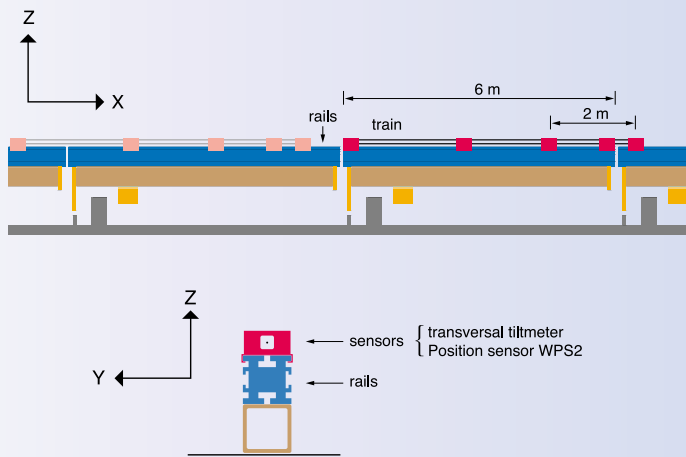
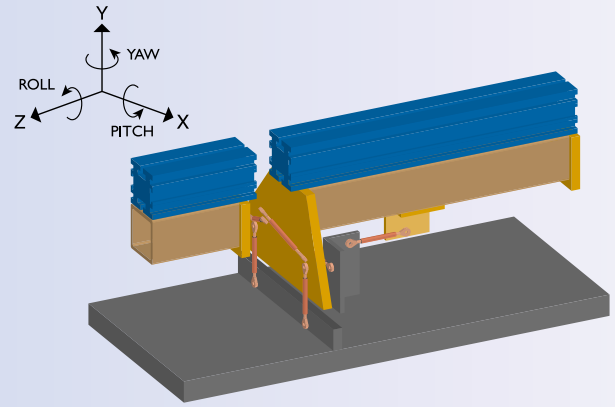

## The concept of the “metrological train”

The 250 m long track consists of 40 beams. Each beam is about 6 m long and several variants of profiles are still investigated. The alignment of the beams will be done in two steps. First, the beam surface is cut-off straight by heavy machinery. Second, the global alignment will be performed by adjusting each beam with the six struts, as explained above.

## The sensors

A non-contact position sensor WPS2 is based on the principle of capacitance and can observe the relative displacement up to 10 mm of a wire with a resolution of 1 μm., in two directions.

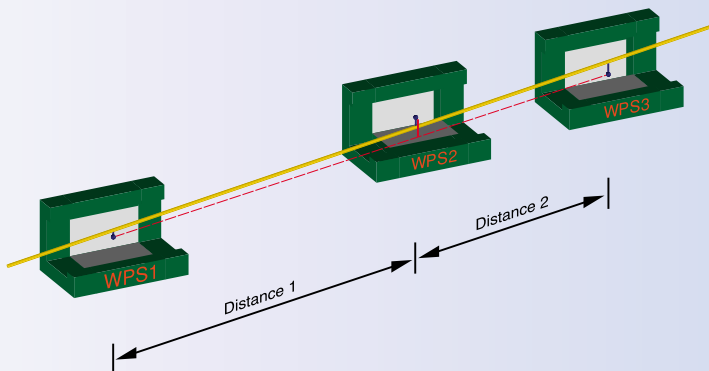
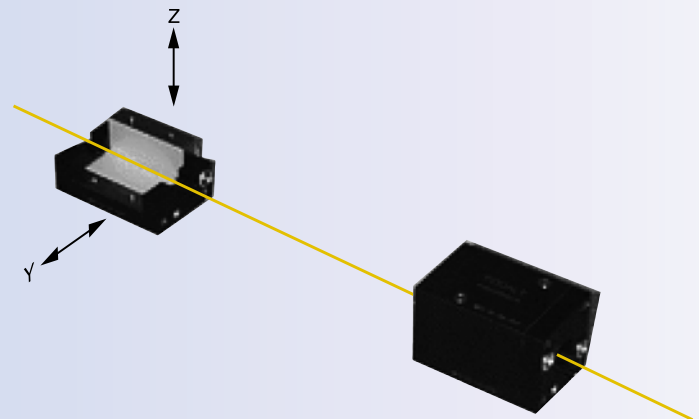

## What we measure - What we compute

A train of 3 sensors gives 3 (blue) measurements. Each measurement corresponds to the distance of the tightened wire with respect to the sensor. These observations allow to compute the misalignment (red) of the central sensor with respect of the two others. This misalignment is an “observable” in a parametric adjustment model.

Each measuring position of a train of n sensors provides n-2 observables, and p alignment points correspond to p-2 unknown parameters, because 2 points are fixed in the reference axis.

- Example:
- 20 points to be aligned, with a train of 5 sensors
  - the train takes 16 measuring positions = 48 observables
  - 20 - 2 alignment points = 18 unknown parameters
  - 48 - 18 = 30 redundant observations