



## OBJECT RECOGNITION WITH VIDEO-THEODOLITES AND WITHOUT TARGETING THE OBJECT

*O.Univ.-Prof.Dr.-Ing. Heribert KAHMEN,  
University of Technology Vienna, Institute of Geodesy and Geophysics,  
A-1040 Vienna, Gusshausstr. 27 - 29/E1283  
Heribert.Kahmen@tuwien.ac.at*

*Eng Cartógrafa Andréa DE SEIXAS  
University of Technology Vienna, Institute of Geodesy and Geophysics,  
A-1040 Vienna, Gusshausstr. 27 - 29/E1283  
aseixas@pop.tuwien.ac.at*

### ABSTRACT

At the Department of Applied Geodesy and Engineering Geodesy (TU Vienna) an new kind of theodolite measurement system is under development, enabling measurements with an accuracy of 1:30.000 with and without targeting the object. The main goal is, to develop an intelligent multi-sensor system. Thus an operator is only needed to supervise the system. Results are gained on-line and can be stored in a CAD system. If no artificial targets are used identification of points has to be performed by the Master-Theodolite. The method, used in our project, is based on interest operators. The Slave-Theodolite has to track the master by searching for homologous regions.

The before described method can only be used, if there is some texture on the surface of the object. If that is not fulfilled, a "gridline-method" can be used, to get informations about the surface of the object. In the case of a Kartesian co-ordinate system, for instance, the gridlines can be chosen by the operator before the measurement process is started. The theodolite-measurement system is then able to detect the grid-lines and to find the positions where the grid-lines intersect the surface of the object.

### 1. COMPUTER CONTROLLED ROTATING CCD-CAMERAS

A theodolite measurement system makes use of the intersections provided by a series of pointings to the same points (targets) by several theodolites to determine co-ordinates of the points measured. For the computation of the point co-ordinates, we use the angle readings on the scale circles of the theodolites pointing to the target. The co-ordinates of the measured points and of the instrument stations are determined by three-dimensional network adjustment. The system is oriented in a given co-ordinate system by reference to control points which form part of that system. In addition these control points provide the scale of the system.

The measurement system is a combination of different components: theodolites used as sensors, computer system, software, accessories.

The sensors used to capture data are computer controlled video-theodolites. A video-theodolite has a CCD-camera in its optical path (fig.1). The horizontal and vertical axes carrying the telescope and the CCD-camera, are driven by motors. The motors are controlled by a computer.

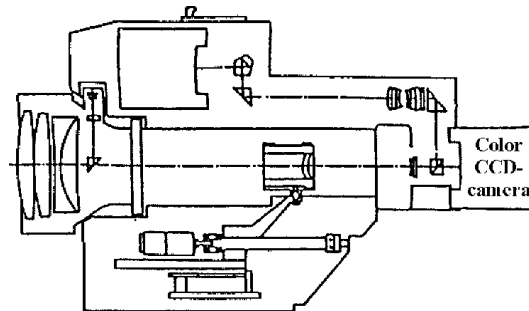

Fig.1:Optical path of a video-theodolite

The images of the telescope's visual field are projected onto the camera's CCD-chip. They consist of the target object and a frame in the focus plain of the telescope replacing the standard telescope reticule. The CCD-camera is capable of capturing mosaic panoramic images through camera rotation. With appropriate calibration these images are accurately georeferenced and orientated as the horizontal and vertical angles of rotation are continuously measured by electronic angle measuring systems and fed into the computer. The oriented images can then be used directly for direction measurements with no need for object control points or photogrammetric orientation processes. The image resolution can be chosen by selecting different camera lenses and should be limited only by the angular precision of the total station.

In practise, the camera system should have two camera lens systems. A wide angle system should provide overview images to support the organization of the measurements and a narrow angle system which provides images for the measurements. The focal length of the narrow angle lense system should be chosen so that the image pixel angle is compatible with the angular precision of the theodolite.

In addition to the motor drives for both theodolite axes, the focusing drive is also motorized. The search for an optimal autofocus distance is controlled by an autofocus function.

With the before described measurement process normally only a small part of the information, produced by the camera for the detection of targets, is used. Therefore a new type of measurement system was under investigation, which enables not only fast and accurate pointing of targets but in addition allows object reconstruction without targeting by using nearly all the information the images contain. In the following the methods enabling objectreconstruction without targeting will be described.

## 2. AN INTERACTIVE MEASUREMENT SYSTEM – A FIRST STEP

The key element of the first system is a vision software which supports the operator to find "natural targets" (extracted features) on the object [Roic, M., 1996]. The diagram of the videometric system is shown in fig.2 . The main steps are image formation, image preprocessing, iconical image processing, image feature extraction, image interpretation and image analysis.



Image formation involves the light source and the object, reflecting the light. The optical image is transformed into a two-dimensional function of the object and stored as a matrix of gray values. The hardware contains amplifiers, A/D-converters, framegrabbers and other devices. The preprocessing software enables the improvement of the radiometric quality of the images and enhancement. Enhancement includes improvement of the geometric quality of the image and data reduction by applying digital filters to

support the feature extraction and positioning phase. Iconical image processing is used to create new images, finally resulting in sets, only containing the desired information. Image feature extraction (segmentation)

comprises searching the objects of interest from the rest of the scene with the aim of partitioning the image into various clusters. Thresholding is a special method in region segmentation assigning "white" to each pixel in the image with gray scale above a particular value. All pixels below this become "black" (fig.3).

Finally the operator has to extract feature information from the enhanced and segmented images and to analyse, if they can be used as targets.

There is no standard telescope reticule in the telescope's visual field, it is replaced by a reference frame. Therefore, for interactive pointing a reticule (identical with the co-ordinate axes of the telescope co-ordinate system) has to be added to the optical system by special image processing software. This reticule then can be used for the alignment of artificial and natural targets on the object.

To test the measurement system, a facade was monitored. Instead of targeting the videometric system, described in fig.2, was used. Sixteen selected edges were monitored (fig.3a). To enhance the edges a Sobel-operator was used combined with histogram equalization and thresholding (fig.3b and c). Fig.4 depicts the standard deviations of the horizontal directions, we got, after we had monitored the detected edges. The facade was monitored with two video-theodolites.

The distance between the object and the theodolites was about 33 m; that leads to an accuracy of the determined edges of  $\pm 2$  mm ( $1 \sigma$ ). The accuracy was only limited by the roughness of the surface. In addition, the observations were performed only with the standard theodolite without using image processing. Then the standard deviations increased to about  $\pm 5$  mm ( $1 \sigma$ ). Other projects showed that the videometric system can also successfully be used for extremely accurate measurement and shape fit of small industrial objects. Accuracies of about 0.1 mm ( $1 \sigma$ ) are possible [Kahmen, H. , Roic, M. , 1995], [Roic, M. , 1996]. The results encouraged us, to start with the development of an automatic system.

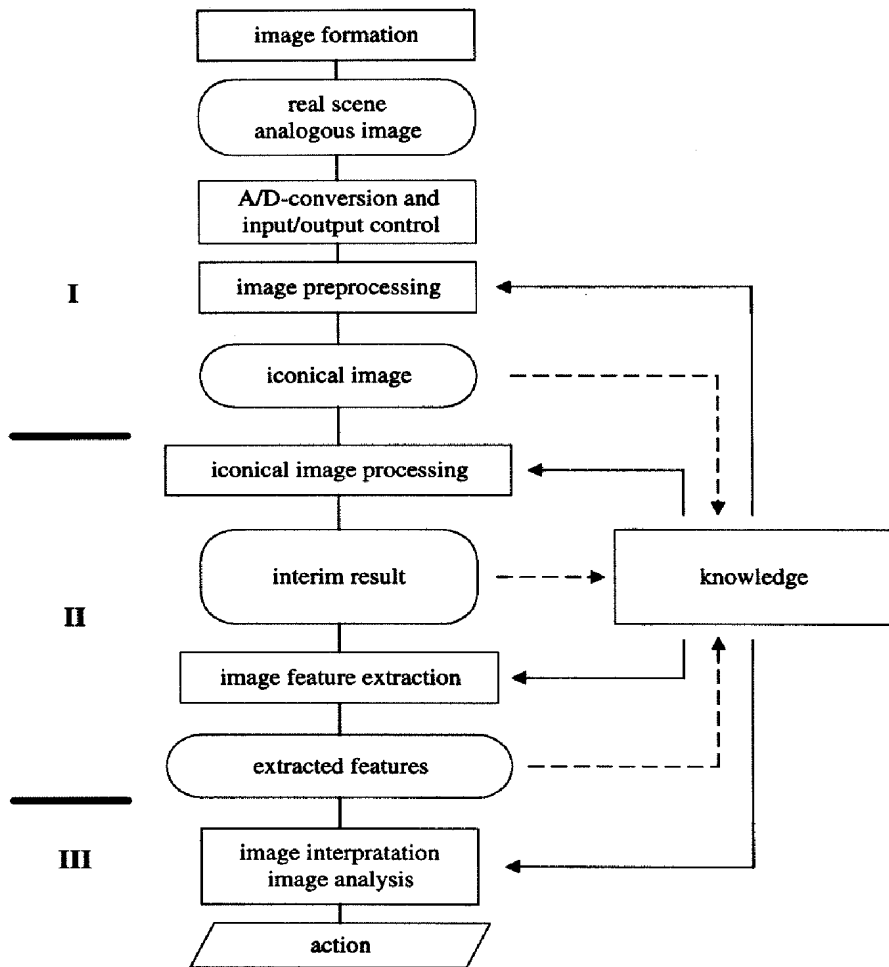

Fig.2:Diagram of videometric system of the theodolites

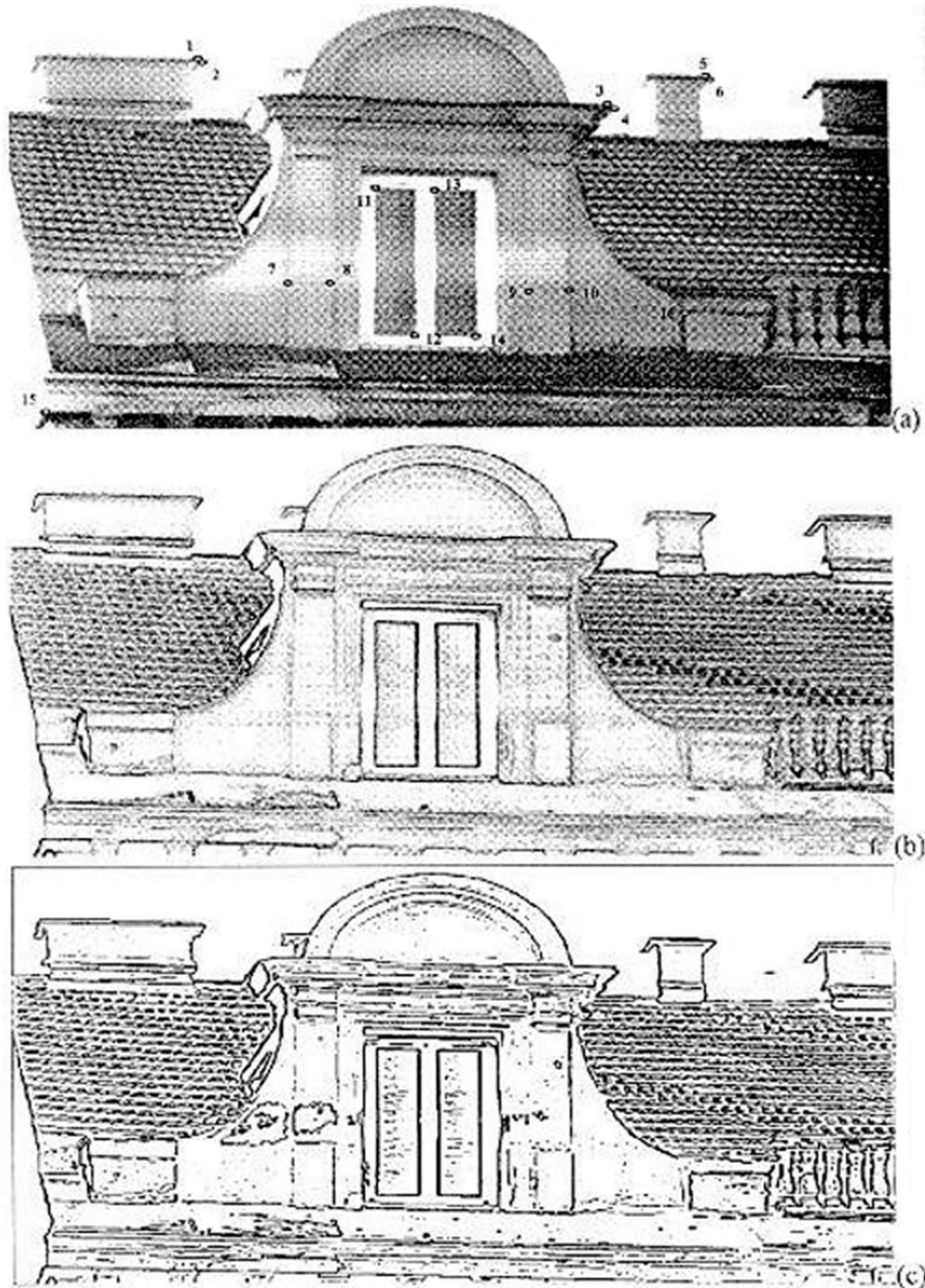

Fig.3:Facade original (a); after applying histogram equalization and Sobel operator (b); after applying thresholding ©



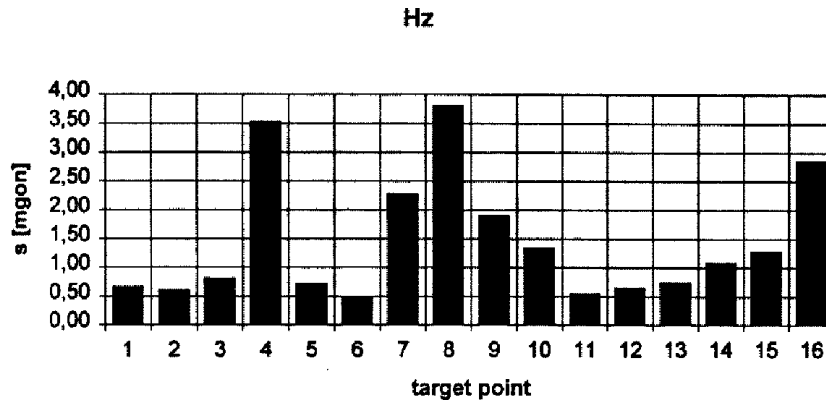

Fig.4: Standard deviation of the horizontal direction

### 3. AN AUTOMATIC SYSTEM – A SECOND STEP

The most effective way to develop an automatic system is, to use the theodolites in a master and slave mode. Then one theodolite (master) scans the object while the second theodolite (slave) tracks it by automatically searching for homologous regions.

Two different scanning procedures were developed: The first method is based on the subposition that there are pattern on the surface of the object to be scanned, or that the object is composed of different structural parts so that corners, intersections of lines or other well marked points can be detected. The second method can be applied without any of these subpositions. The first scanning method works with an interest operator, the second with different grid-line methods.

#### 3 1 Scanning method, based on an interest operator

The procedure is described in fig.5 [Mischke, A. , 1997]. Scanning of the object is started with the master theodolite; scanning means that points of interest have to be detected, which finally can describe the 3D surface of the object. This can be performed with interest operators. We decided to take the Förstner Operator. With the Förstner Operator a wide field of different points can be located with subpixel accuracy: points on lines or edges, centers of symmetrical figures, intersections of lines, edges.

The speed, accuracy and reliability of the Förstner Operator depends on the quality of the images, the number of pixels to be processed and limiting parameters chosen by the user. In our systems it is possible to use the operator for the total image or a predestined region of interest. For all points, identified with the Förstner Operator on the surface of the object, image co-ordinates are stored in a list.

In addition they can be marked on the screen to help the operator to decide, if they should be used for object reconstruction or not. While the master theodolite is scanning the object, the slave has to track it in order to find homologous regions and finally the homologous points. For the tracking procedure the collimation axis of the master theodolite is used (fig.6).

This method is very time-consuming if there are no approximate co-ordinates of those points  $P_i$  of interest available, the master theodolite had identified. These approximate values can be calculated with the approximate distance  $\overline{T_I P_i}$ , we get from the autofocus function of the master.

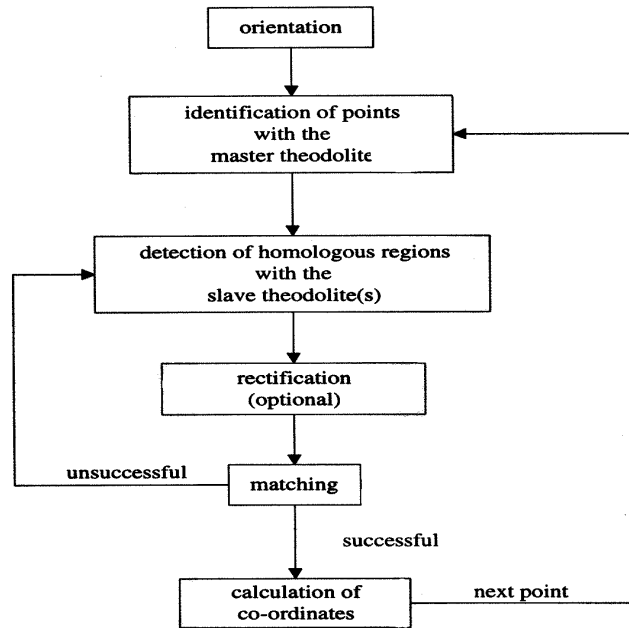

Fig.5: Diagram of the automatic measurement system

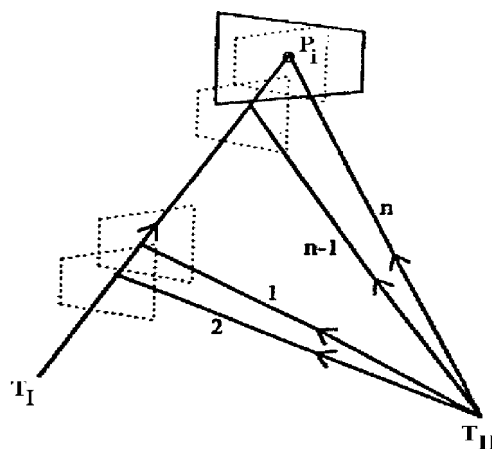

Fig.6: The tracking procedure of the slave theodolite

For the slave theodolite a very fast tracking algorithm has been developed by making use of the epipolar line geometry. An epipolar line is given by the intersection of two plains. Here one plain is defined by the points  $T_I, T_{II}$  and  $P_i$  and the second plain is given by the CCD-array of the slave.  $T_I$  and  $T_{II}$  are the intersection points of the principal axes of the theodolites.

Fig.7 shows how the intersections of the epipolar line and the frame of the CCD-array can be used to control the slave theodolites. After the co-ordinates of the intersection points are determined with respect to the theodolite co-ordinate system correction angles can be calculated by which the collimation axis of the slave can be moved along the epipolar line.

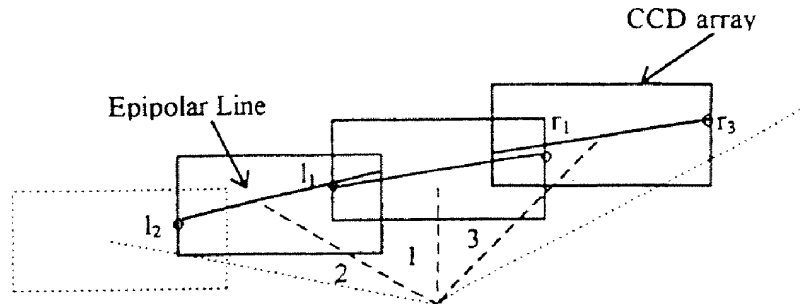

Fig.7: The tracking procedure by using the epipolar line

This tracking procedure starts at one intersection point and stops at the other. If the searching procedure was without success the axes of the theodolite have to be moved for some steps and further epipolar lines have to be determined in the neighborhood of the first one.

Simultaneous with the tracking procedure a search algorithm is used to detect homologous regions and points with respect to the master theodolite by a matching procedure. In our case least squares matching was used. With the image co-ordinates, determined with the camera of the master and slave, horizontal and vertical angles of the theodolite measurement system are calculated which can then be used to compute the object co-ordinates by spatial intersection or three dimensional network adjustment.

### 3 2 Scanning method, based on different grid-line methods

For this method, the measurement system has to be modified in such a way that regularly arranged virtual grid-lines of the 3D object co-ordinate system can be created. The grid-lines can be chosen a priori and shall intersect the surface of the object to be reconstructed. Fig.8 depicts with a very simple example, how regularly arranged grid-lines of a Cartesian co-ordinate system intersect an object, which has the form of a cuboid.

We get grid-lines parallel to the y-axis, if the x- and z- co-ordinates are kept constant, grid-lines parallel to the x-axis, if the y- and z- co-ordinates are kept constant and grid-lines parallel to the z-axis, if the y- and x- co-ordinates are kept constant. The intersection points can then be used for 3D object reconstruction. The density of the points of interest depends on the density of the grid-lines and should be chosen such that 3D reconstruction of the object is possible without loss of accuracy.



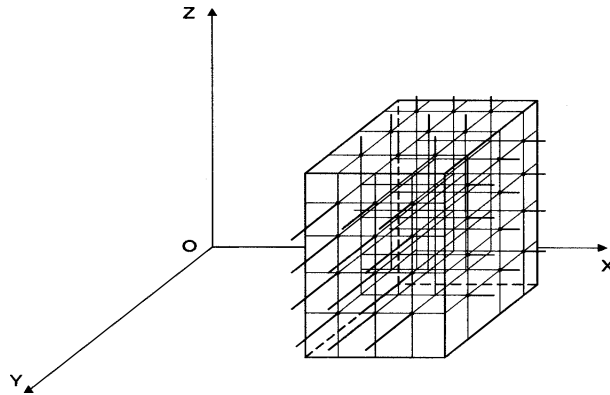

Fig.8: Lines intersect the surface of an object

The modified measurement system consists of a laser-theodolite (master) and a video-theodolite (slave). The laser-theodolite is coupled to a laser generator of a visible laser beam which projects target points on the object. To ensure maximum contrast between the target and the surface of the object during measurement, the intensity of the laser should automatically be adjusted.

The video-theodolite is automatically pointed at the same time as the pointer-theodolite. As soon as the target point appears in the visual field, the video-theodolite identifies it and determines its position on the CCD-array. Computation of the point of intersection  $P_i$  of the two space directions which represent the two lines-of-sight produces the effective point co-ordinates. Fig.9 shows the surface of an object and point  $P_i$ , where the laser hits the surface. While scanning the object the laser target point has to be moved as long until it is identical with points  $P_s$ , where the grid-line intersects the surface.

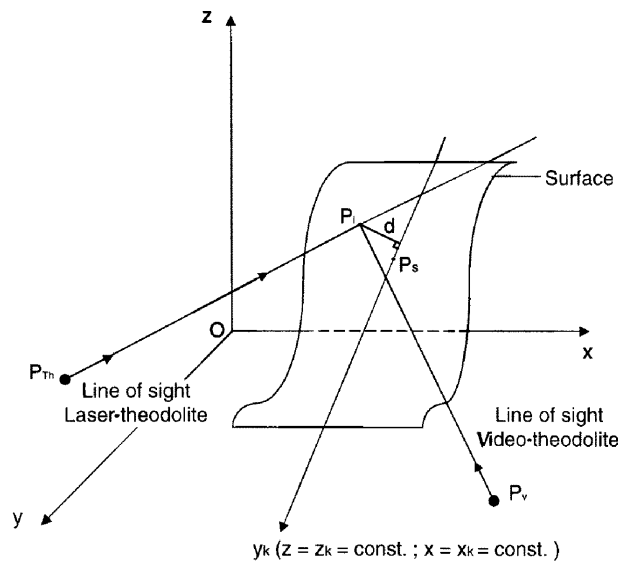

Fig.9: Principle of the measurements with laser- and video-theodolite

Different iterative methods were developed to get the intersection points by scanning [Seixas, A. , 1999]. All methods are in common with that the shortest distance

$$d = \sqrt{(\Delta x_{is})^2 + (\Delta z_{is})^2} \quad (1)$$

between the laser beam and the grid-line  $y_k$  has to be minimized. The co-ordinate differences are defined as

$$\begin{aligned} \Delta x_{is} &= x_i - x_s = \rho \cos Hz \sin V - x_k \\ \Delta z_{is} &= z_i - z_s = \rho \cos V - z_k. \end{aligned} \quad (2)$$

$H_z$  (horizontal angle) and  $V$  (vertical angle) are measured with the laser-theodolite.  $\rho$  is the distance between the position  $P_{Th}$  of the laser-theodolite and  $P_i$ . As the co-ordinates of  $P_{Th}$  and  $P_i$  are known from the intersection procedure,  $\rho$  is well known. Consequently  $d$  can be written

$$d = f(Hz, V). \quad (3)$$

Here only the Gradient Method shall be mentioned. If  $P_i(x_i, y_i, z_i)$  is a point in the neighborhood of the searched minimum, then the new point  $P_S(x_S, y_S, z_S)$  is searched in the direction of the gradient of  $f(Hz, V)$  by:

$$\begin{bmatrix} Hz_{k+1} \\ V_{k+1} \end{bmatrix} = \begin{bmatrix} Hz_k \\ V_k \end{bmatrix} + h_k \frac{g_k}{|g_k|} = \begin{bmatrix} Hz_k \\ V_k \end{bmatrix} + h_k u_k \quad (4)$$

with  $g_k = \text{grad } f(Hz, V)$ .

The minimization procedure comprises seven steps:

- Computation of point  $P_i$  by spatial intersection
- Evaluate the gradient  $g_k = \text{grad } f(Hz, V)$  at point  $P_i$
- Compute the search direction  $u_k = -\frac{g_k}{|g_k|}$
- Perform a linear search in the search direction by choosing  $h_k$
- Generate a new point  $x_{k+1} = x_k + h_k u_k$
- The process must then be repeated iteratively by setting  $k=k+1$  and going back to step 2
- The iterative process is stopped if step  $h_k u_k$ , taken at iteration  $k$ , is less then the the positioning error caused by resolution of the angle measurement systems of theodolites.

If the object, to be monitored, is rotationally symmetrical or a sphere it can be advantageous to use a cylindrical or a spherical object co-ordinate system for 3D object reconstruction. In that case

the grid-lines have to be adapted to these co-ordinate systems. Sometimes it can be useful to combine different co-ordinate system. Then complex surfaces, like shown in fig.10, can be covered with regularly arranged measurement points.

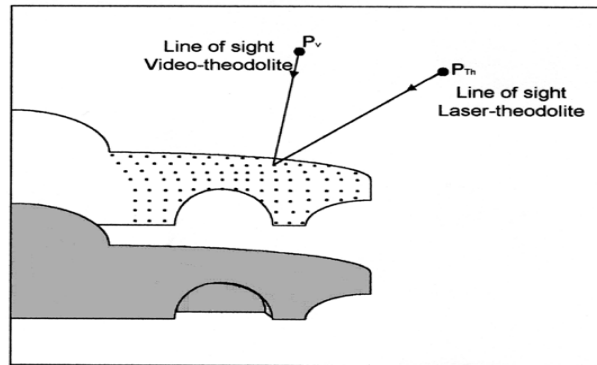

Fig.10: An application of scanning complex surfaces with the grid-line method

#### 4. OUTLOOK

Surveying of objects with a complex surface will only be possible if all the knowledge is available, the operator normally adds to the measuring system. Then decision making of the measurement system will be possible, based on semantic analysis. Further investigations of a knowledge based system will therefore be the main goal in the future. Complex surfaces, as shown in fig.3 and e.g. frameworks, as depicted in fig.11 can then be reconstructed.



Fig.11: Automatic deformation monitoring of frameworks as an example of a main goal for future research

## References

- [1] KAHMEN, H., ROIC, M., 1995. A new Generation of Measurement Robots for Object Reconstruction without Targeting. In A. Grün and H. Kahmen, editors, Optical 3-D Measurement III, pages 251-262, Karlsruhe, Germany. Herbert Wichmann Verlag.
- [2] MISCHKE, A., 1998. Entwicklung eines Videotheodolit-Meßsystems zur automatischen Richtungsmessung von nicht signalisierten Objekten. PhD thesis, Department of Engineering Surveying, Vienna University of Technology.
- [3] ROIC, M., 1996. Erfassung von nicht signalisierten 3D-Strukturen mit Videotheodoliten, Volume 43 of Geowissenschaftliche Mitteilung der Studienrichtung Vermessungswesen. Department of Engineering Surveying, Vienna University of Technology. PhD thesis.
- [4] SEIXAS, A., 1999. 3D Object Reconstruction with Different Grid-line Methods. PhD thesis, Department of Engineering Surveying, Vienna University of Technology. In preparation.