

Machine Safeguarding General Methods and Options

Department: Chemical and General Safety

Program: Machine Safeguarding

Owner: Program Manager, Linda Knudsen

Authority: ES&H Manual, Chapter 39, Machine Safeguarding

If a machine-specific evaluation or other inspection reveals areas of the machine whose moving parts pose a potential hazard to operators or others nearby, guarding can be accomplished by one or a combination of the methods below.¹

Whichever safeguard or combination of safeguards is chosen, it must

1. Prevent the worker's body or clothing from contacting hazardous moving parts
2. Be firmly secured to machine and not easily removed
3. Not allow falling objects to enter moving parts
4. Create no new hazards (must not have shear points, jagged edges or unfinished surfaces)
5. Create no interference (must not prevent worker from performing the job quickly and comfortably)
6. Allow safe lubrication (the person should be able to lubricate the machine without removing the safeguard)

Guards

Fixed

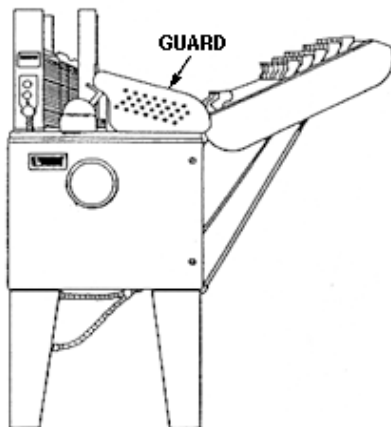

A fixed guard provides a barrier, a permanent part of the machine, preferable to all other types of guards.

1 Content based on federal OSHA Publication 3067, "Concepts and Techniques of Machine Safeguarding", and Lawrence Berkeley Lab *Health and Safety Manual*, Chapter 5.3, "Machine Safeguarding"

Interlocked

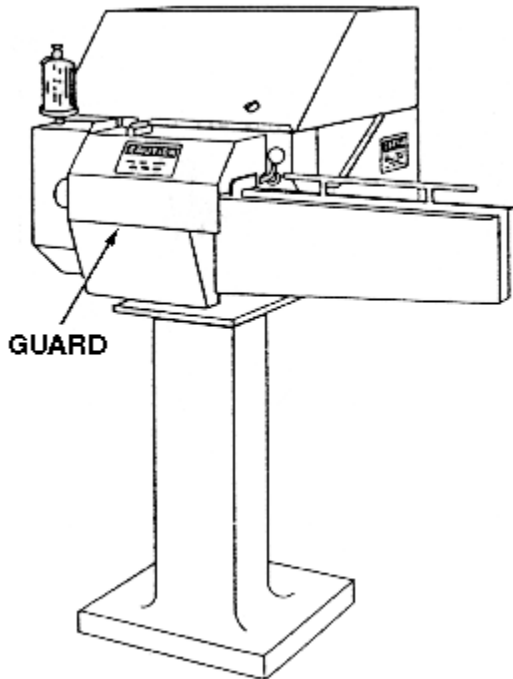

When an interlocked guard is opened or removed, the tripping mechanism or power automatically shuts off or disengages, and the machine cannot cycle or be started until the guard is back in place.

Adjustable

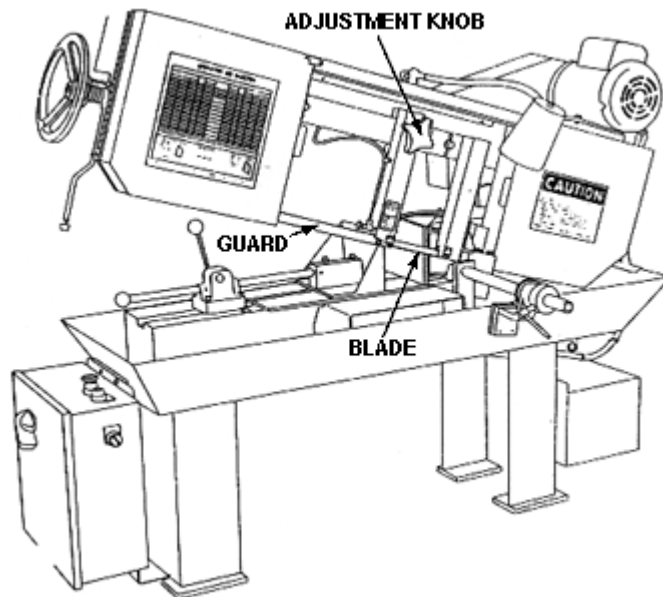

An adjustable guard provides a barrier that may be adjusted to facilitate a variety of production operations. Adjustable guards are useful because they allow flexibility in

accommodating various sizes of stock, but, because they require adjusting, they are subject to human error.

Self-adjusting

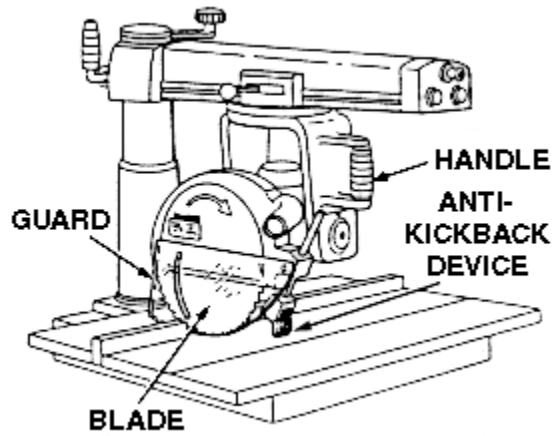

A self-adjusting guard provides a barrier that moves according to the size of the stock entering the danger area. Self-adjusting guards avoid the potential for human error associated with adjustable guards.

Safety Devices

A safety device may perform one of several functions:

- It may stop the machine if a hand or any part of the body is inadvertently placed in the danger area.
- It may restrain or withdraw the operator's hands from the danger area during operation.
- It may require the operator to use both hands on machine controls, thus keeping both hands and body out of danger.
- It may provide a barrier that is synchronized with the operating cycle of the machine in order to prevent entry to the danger area during the hazardous part of the cycle.

Presence Sensing

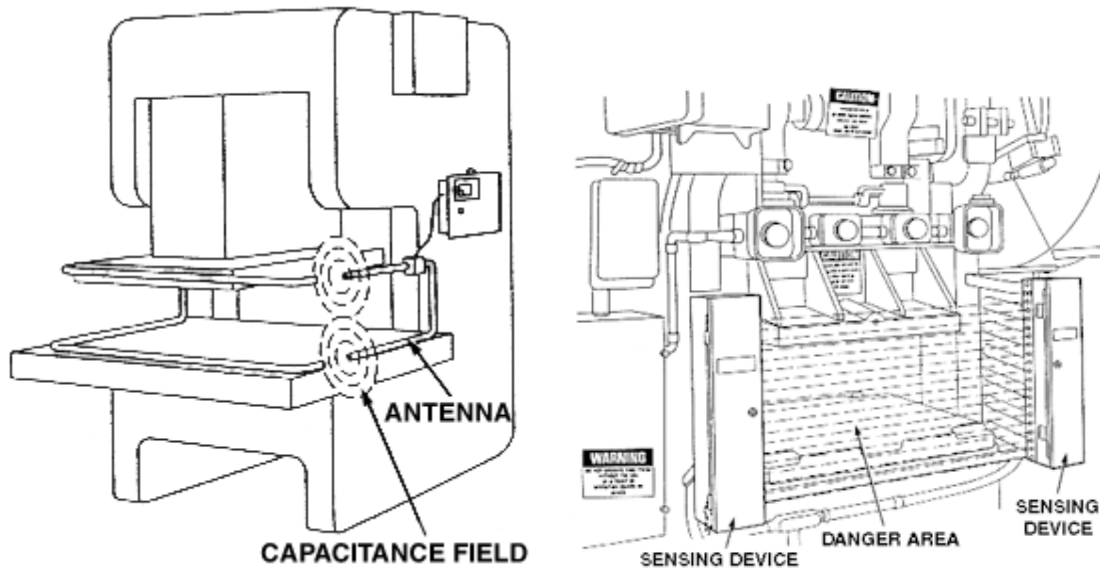

Presence-sensing devices: radio frequency (capacitance) (left); photoelectrical (optical) (right)

A presence-sensing device uses a system of light or radio beam (capacitance) sources and controls that can interrupt the machine's operating cycle. If the sensing field is broken, the machine stops and will not cycle. This device must be used only on machines that can be stopped before the worker can reach the danger area. The design and placement of the guard depends upon the time it takes to stop the mechanism and the speed at which the person's hand can reach across the distance from the guard to the danger zone.

Electromechanical Sensing Device

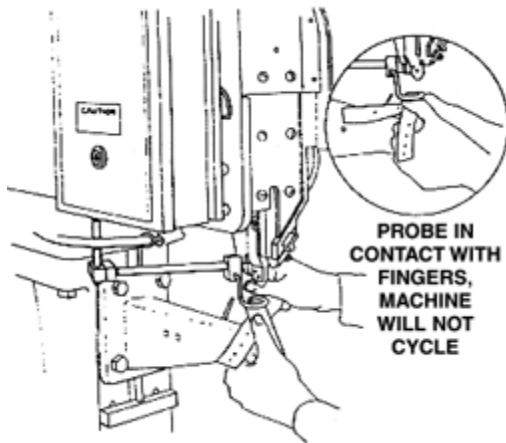

An electromechanical presence-sensing device has a probe or contact bar that descends to a predetermined distance when the operator initiates the machine cycle. If there is an obstruction preventing it from descending its full pre-determined distance, the control unit does not actuate the machine cycle.

Pullback

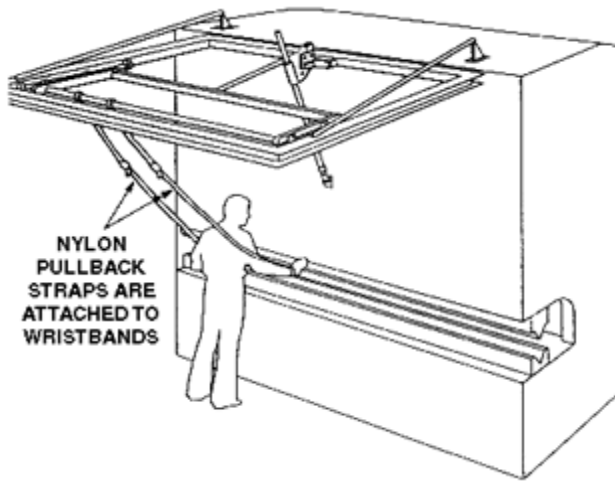

A pullback utilizes a series of cables attached to the operator's hands, wrists, or arms which withdraws hands when the slide/ram begins to descend. It is primarily used on machines with full-revolution stroking action and allows access to the point of operation when the slide/ram is up.

Restraint

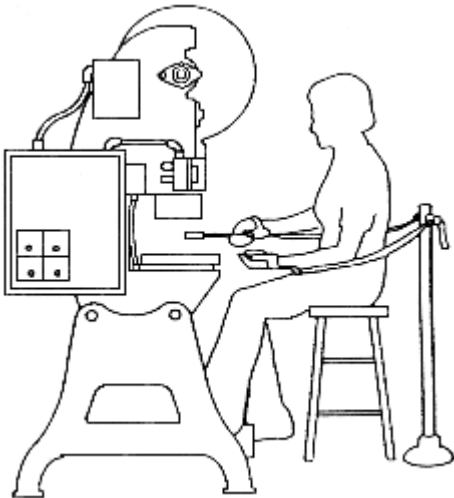

A restraint uses cables or straps attached to the operator's hands and a fixed point. It must be adjusted to let the operator's hands travel within a predetermined safe area.

Safety Controls

Pressure-sensitive Body Bar

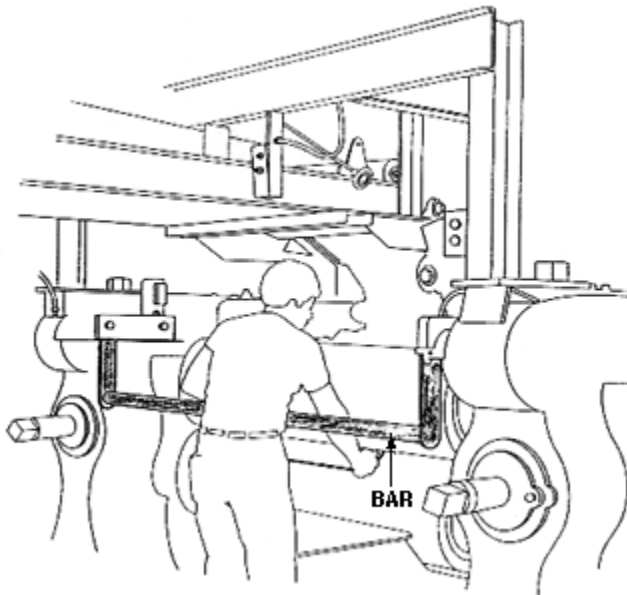

When depressed, a pressure-sensitive body bar will deactivate the machine. If the operator or anyone trips, loses balance, or is drawn into the machine, applying pressure to the bar will stop the operation.

Safety Tripod

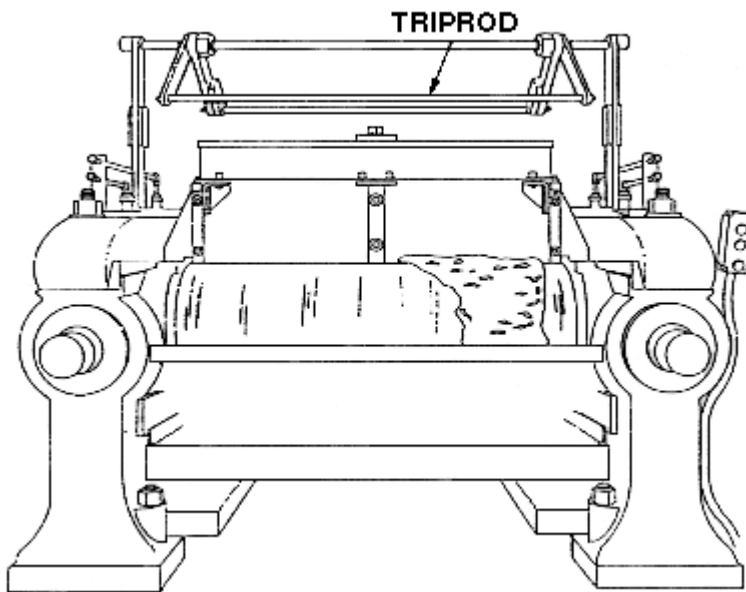

When pressed by the operator's hand, a safety tripod deactivates the machine. Because it has to be actuated by the operator during emergency situations, proper position is critical.

Safety Tripwire Cable

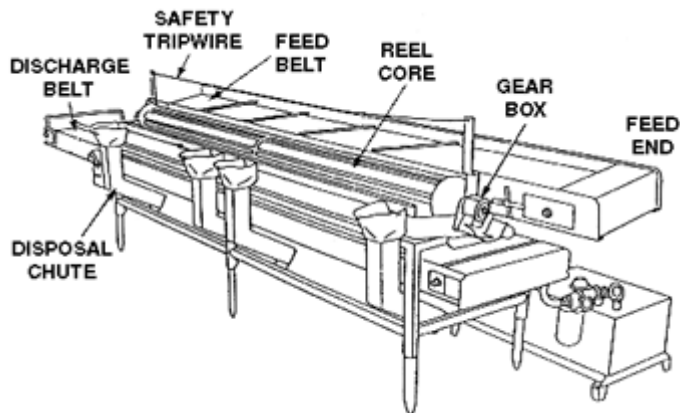

A safety tripwire cable is a device located around the perimeter of or near the danger area. Operator must be able to reach the cable to stop the machine. Tripwire cables must be manually reset to restart the machine.

Two-hand Control

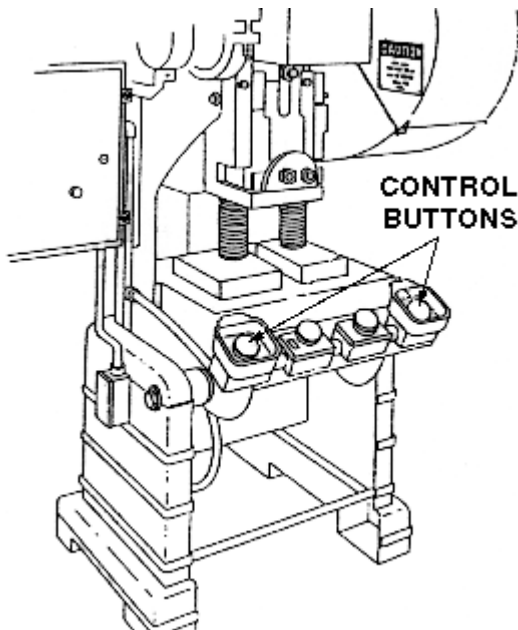

A two-hand control requires constant, concurrent pressure to activate the machine. This kind of control requires a part-revolution clutch, brake, and a brake monitor if used on a power press. The operator's hands are required to be at a safe location (on control buttons) and at a safe distance from the danger area while the machine completes its closing cycle.

Two-hand Trip

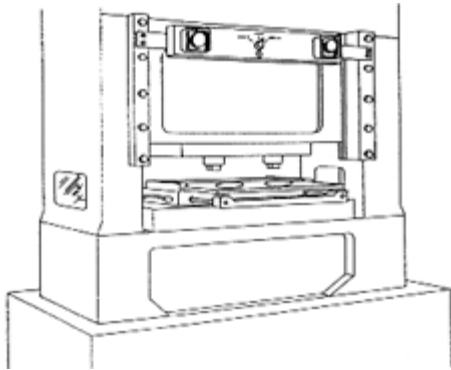

A two-hand trip requires concurrent application of both of the operator's control buttons to activate the machine cycle, after which the hands are free. This device is used with machines equipped with full-revolution clutches. The trips must be placed far enough from the point of operation to make it impossible for the operators to move their hands from the trip buttons or handles into the point of operation before the first half of the cycle is completed to prevent them from being accidentally placed in the danger area prior to the slide/ram or blade reaching the full "down" position.

Gate

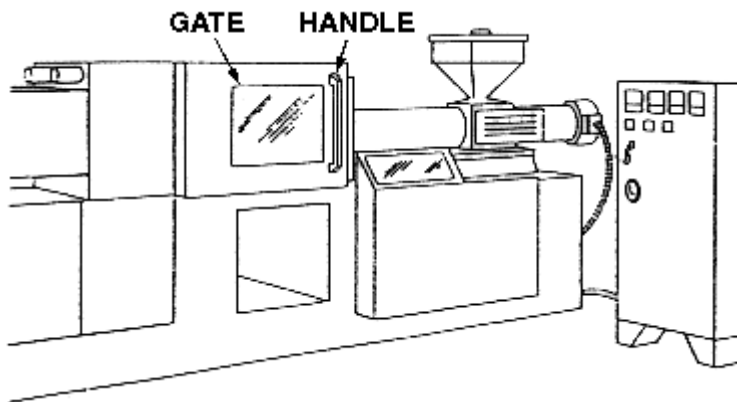

Gates are movable barriers that protect the operator at the point of operation before the machine cycle text can be started. Gates are, in many instances, designed to be operated with each machine cycle. If the gate does not fully close, machine will not function.

Guarding by Location/Distance

Locate the machine and its dangerous moving parts so that they are not accessible or do not present a hazard to a worker during normal operation. Maintain a safe distance from the danger area. To consider a part of a machine to be safeguarded by location, the dangerous moving part of a machine must be so positioned that those areas are not accessible or do not present a hazard to a worker during the normal operation of the machine. This may be accomplished by locating a machine so that the hazardous parts of the machine are located away from operator work stations or other areas where employees walk or work. Additionally, enclosure walls or fences can restrict access to

machines. Another possible solution is to have dangerous parts located high enough to be out of the normal reach of any worker.

Feeding and Ejection Methods

Many feeding and ejection methods do not require operators to place their hands in the danger area. In some cases, no operator involvement is necessary after the machine is set up. In other situations, operators can manually feed the stock with the assistance of a feeding mechanism. Properly designed ejection methods do not require operator involvement after the machine starts to function. Using feeding and ejection methods does not eliminate the need for safeguarding. Guards and other devices must be used wherever they are necessary to provide protection from hazards. Automatic feeds reduce the operator exposure during the work process, and sometimes do not require any effort by the operator after the machine is set up and running.

Miscellaneous Aids

Although these aids do not give complete protection from machine hazards, they may provide the operator with an extra margin of safety. Sound judgment is needed in their use.

Awareness Barriers

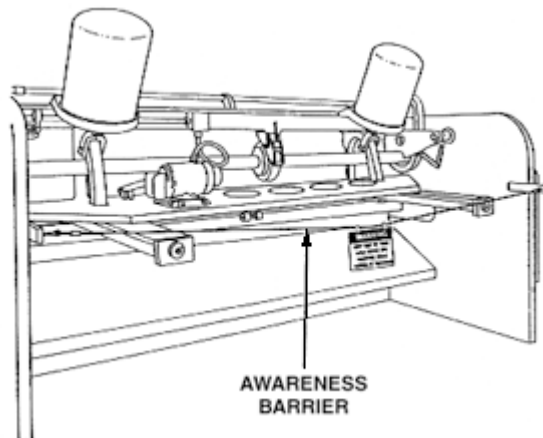

Awareness barriers do not provide physical protection but serve only as reminders to a person that he or she is approaching the danger area. Generally, awareness barriers are not considered adequate where continual exposure to the hazard exists.

Protective Shields

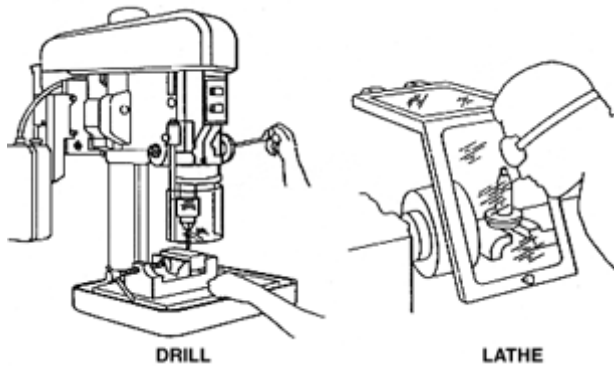

Aids such as clear protective shields do not give complete protection from machine hazards, but do provide some protection from flying particles, splashing cutting oils, and coolants. They provide the operator with an extra margin of safety.

Hand-feeding or retrieving Tools

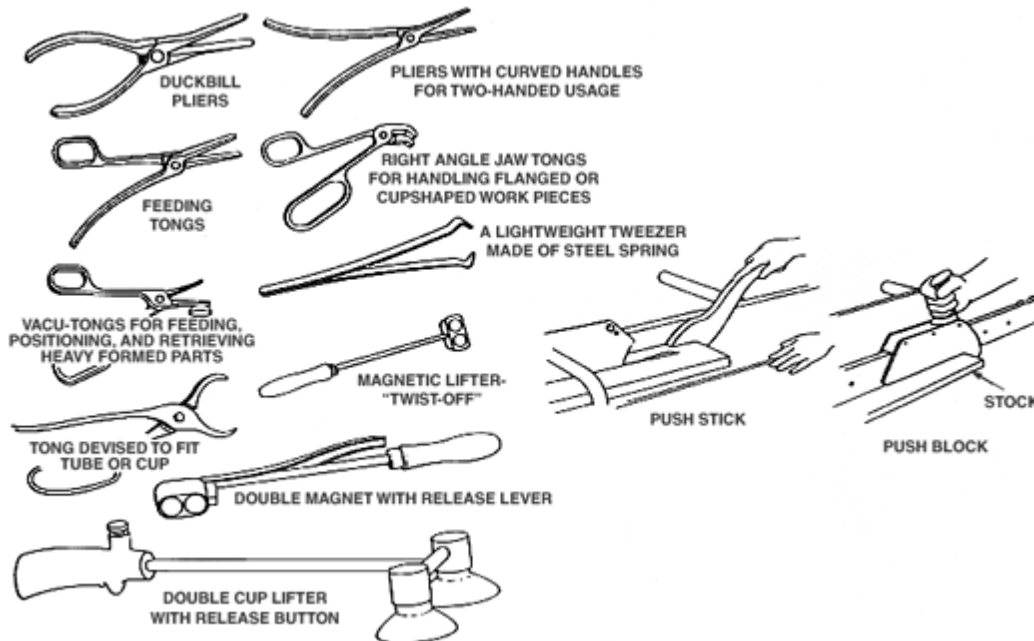

Hand-feeding or retrieving tools can place or remove stock. Hand-feeding tools are intended for placing and removing materials into the in the danger area of a machine. Hand-feeding tools are not a point-of-operation guard or protection device and shall not be used in lieu of appropriate safeguards, but as a supplement. A typical use would be for reaching in the danger area of a press or press brake. Another example would be a push stick or block used when feeding stock into a saw blade. When it becomes necessary for hands to be in close proximity to the blade, the push stick or block may provide a few inches of safety and prevent a severe injury.

Guard Construction

Builders of many single-purpose machines provide point-of-operation and power-transmission safeguards as standard equipment. Unfortunately, not all machines in use have built-in safeguards provided by the manufacturer.

Guards designed and built by the manufacturer offer two main advantages:

1. They usually conform to the design and function of the machine.
2. They can be designed to strengthen the machine in some way or to serve some additional functional purposes.

Guards fabricated by the machine tool user are sometimes necessary for a variety of reasons, and offer these advantages:

- Often, with older machinery, they are the only practical solution.
- In older plants, they may be the only choice for mechanical power transmission apparatus, where machinery is not powered by individual motor drives.
- They permit options for point-of-operation safeguards when skilled personnel and machinery are available to make them.
- They can be designed and built to fit unique and even changing situations.
- They can be installed on individual dies and feeding mechanisms.

User-fabricated guards also have disadvantages. They may

- Not conform well to the configuration and function of the machine
- Be poorly designed or built
- Not comply with regulatory requirements