

# **Improvement Schemes to SASE FELs**

**Zhirong Huang**

BIG meeting

1/31/2003

# SASE: Transverse Coherence

- Spontaneous undulator radiation phase space is the incoherent sum of the electron phase space, consists of many spatial modes

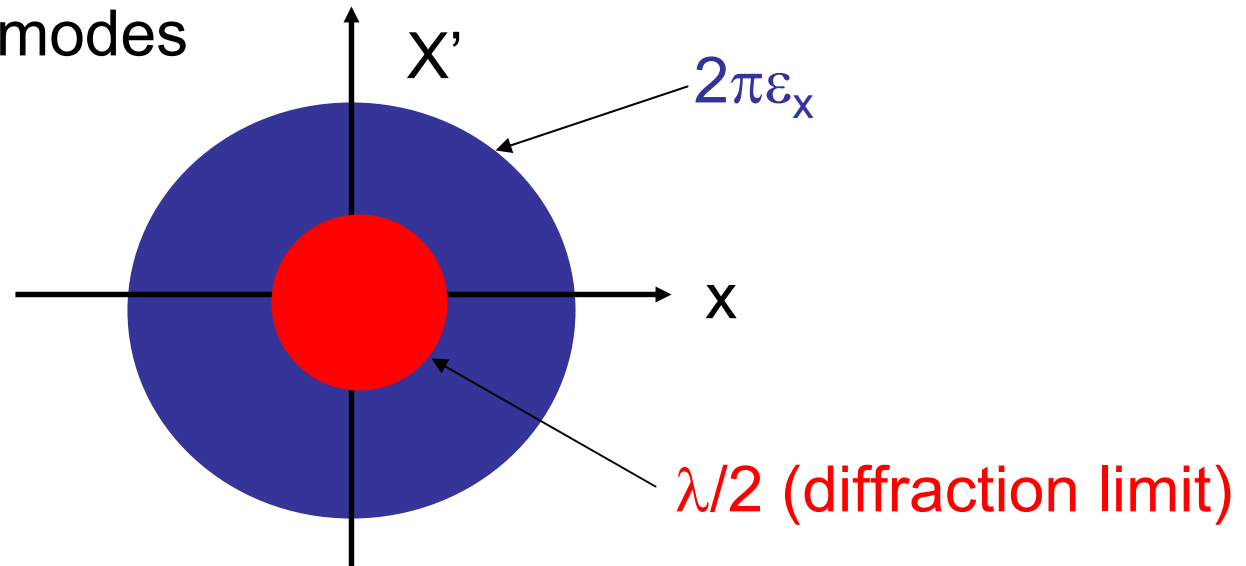

- SASE: higher-order modes have stronger diffraction + FEL gain is localized within the electrons
  - selection of the fundamental mode (gain guiding)
  - Fully transversely coherent even  $\varepsilon_x > \lambda/(4\pi)$  (large  $L_G$ )

# SASE: Temporal Coherence

- $E(t) = \sum_j E_0(t-t_j)$ ,  $t_j$  is the random arrival time of  $j^{\text{th}}$   $e^-$

$E_0$ : wave packet of a single  $e^-$

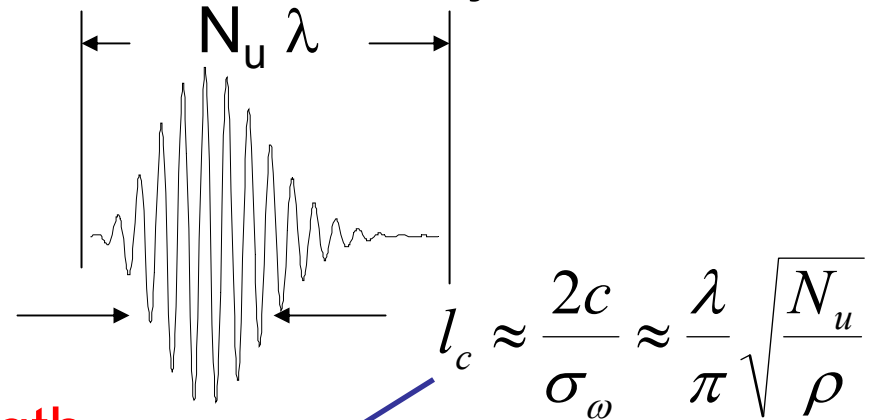

- $l_c \sim 100-1000 \lambda < \text{bunch length}$

- Sum of all packets  $\rightarrow E(t)$

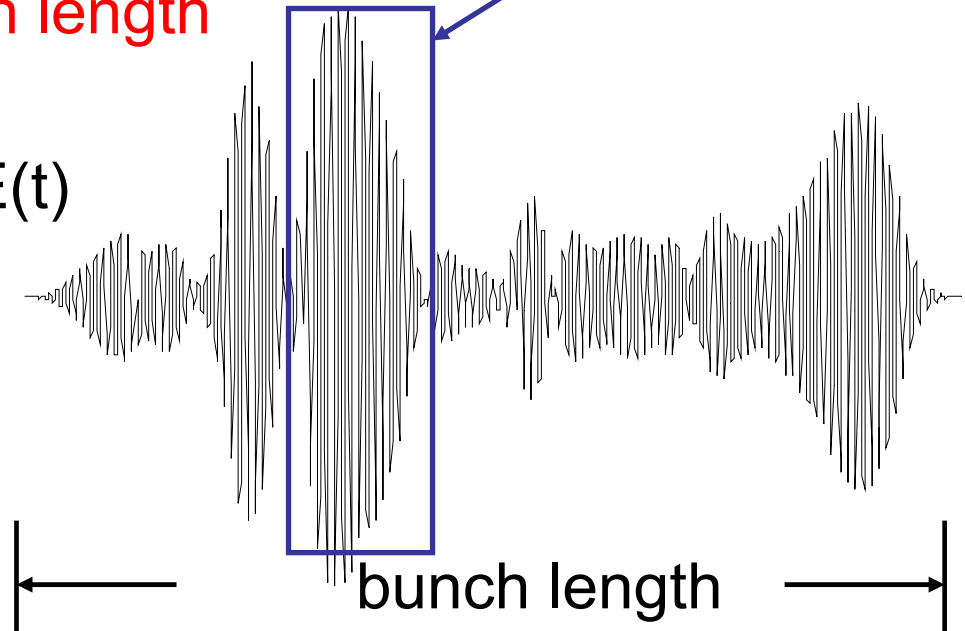

# Statistical Fluctuation

- Due to noise start-up, SASE is a chaotic light temporally with  $M$  modes ( $\sim M$  spikes in intensity profile)

$$M \approx \frac{\text{bunch length}}{\text{coherence length}}$$

- Its longitudinal phase space is  $\sim M$  larger than FT limit (rooms for improve!)

- Total energy fluctuation  $\frac{\sigma_W}{W} = \frac{1}{\sqrt{M}}$

- SASE pulse length is comparable to electron bunch length  $\sim 100$  fs (if flattop), can be shorter if bunch shape has spikes

- LCLS near saturation (80 m)

Coherence time 0.3 fs

number of spikes ~ 400

number of modes ~ 600

→  $\sigma_w/W \sim 4 \%$  (small!)

- If monochromatized,  $M=1$

→  $\sigma_w/W \sim 100 \%$  (even after saturation)

Avg. Field Power vs. Z

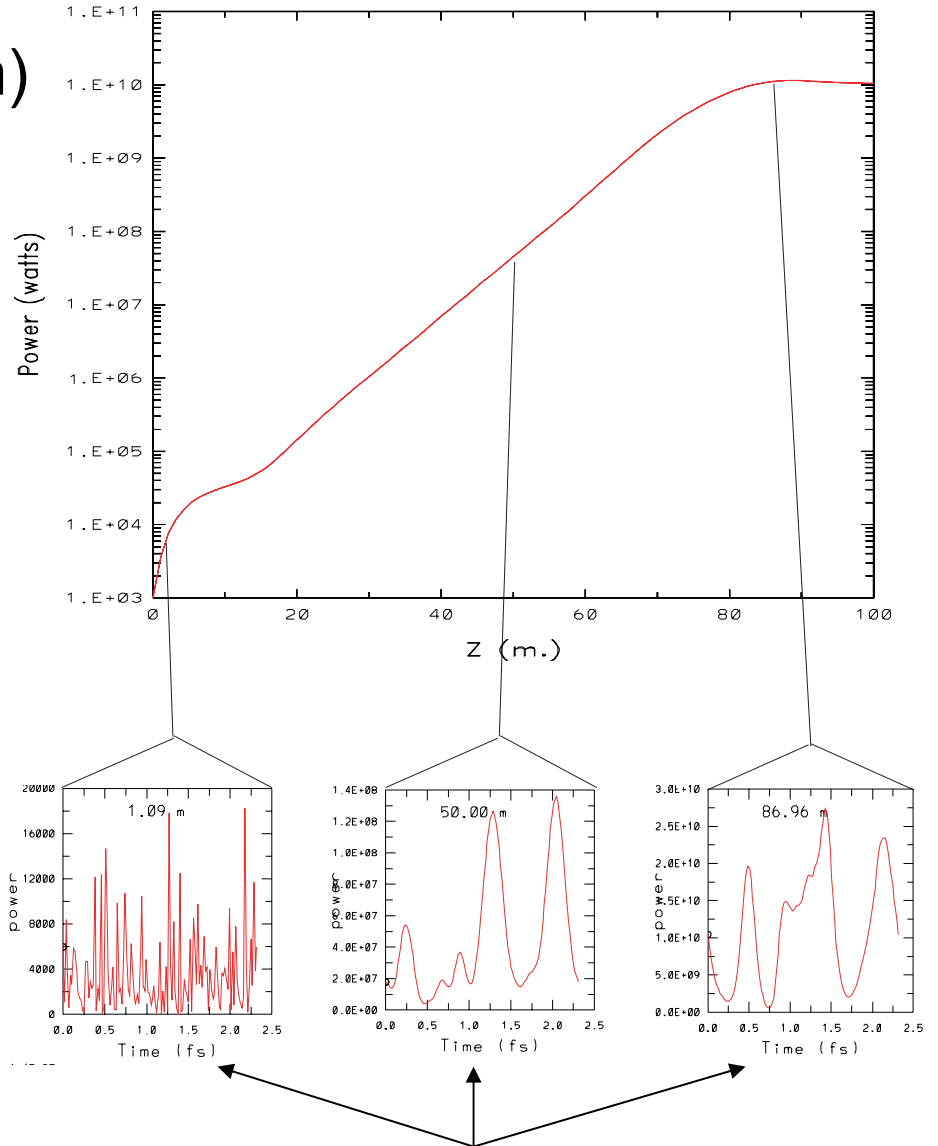

# Survey of Improvement Schemes

- Longitudinal properties of SASE can be improved
- narrower bandwidth (through seeds or feedbacks)
  - External seed: HGHG
  - Self-seed: two-stage
  - Feedback: RAFEL
- Shorter x-ray pulses
  - X-ray manipulation of a frequency-chirped SASE
  - Electron bunch manipulation
  - Sub fs possibilities

# HGHG Principle (L.-H. Yu)

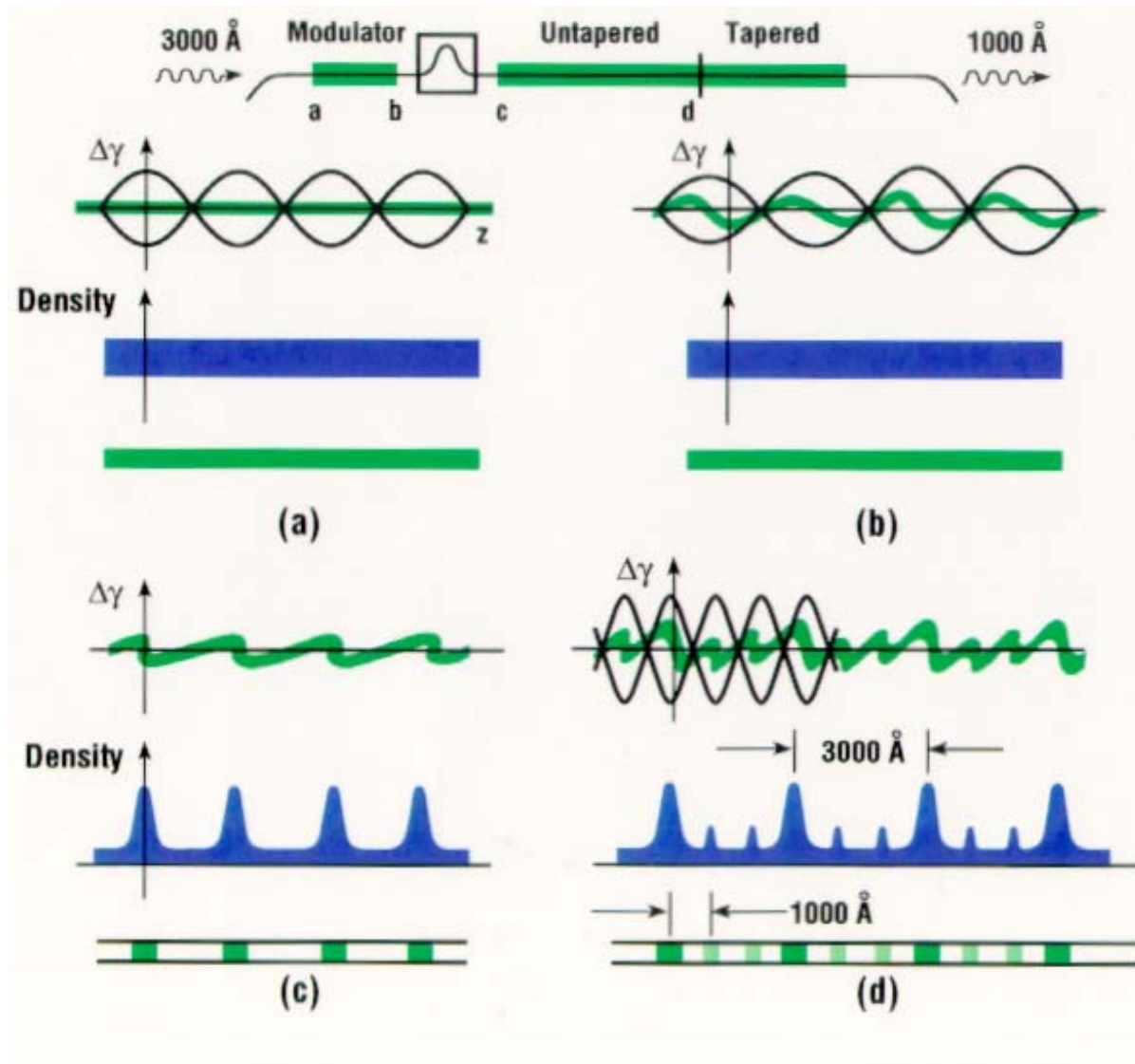

## Advantages of HGHG

- Narrow bandwidth

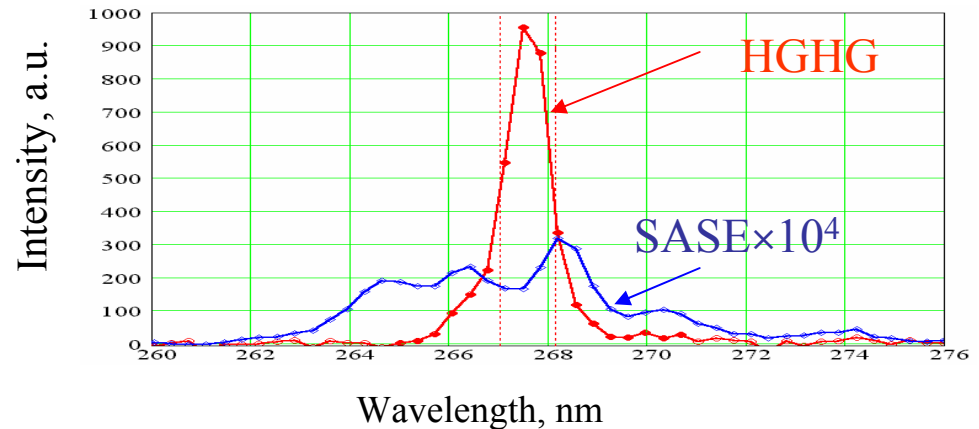

- Stable central wavelength
- Fourier transform limited
- Larger ratio of output/spontaneous radiation
- Short pulse (20fs)
- Stable Intensity from shot to shot
- Can be cascaded to short wavelength

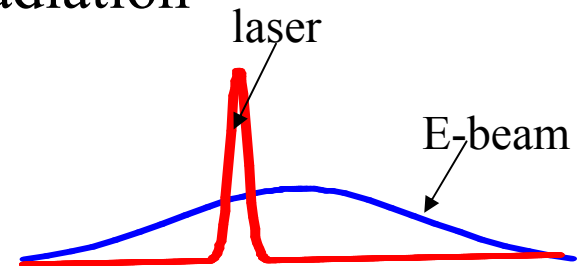

# Soft X-Ray Free-Electron Laser

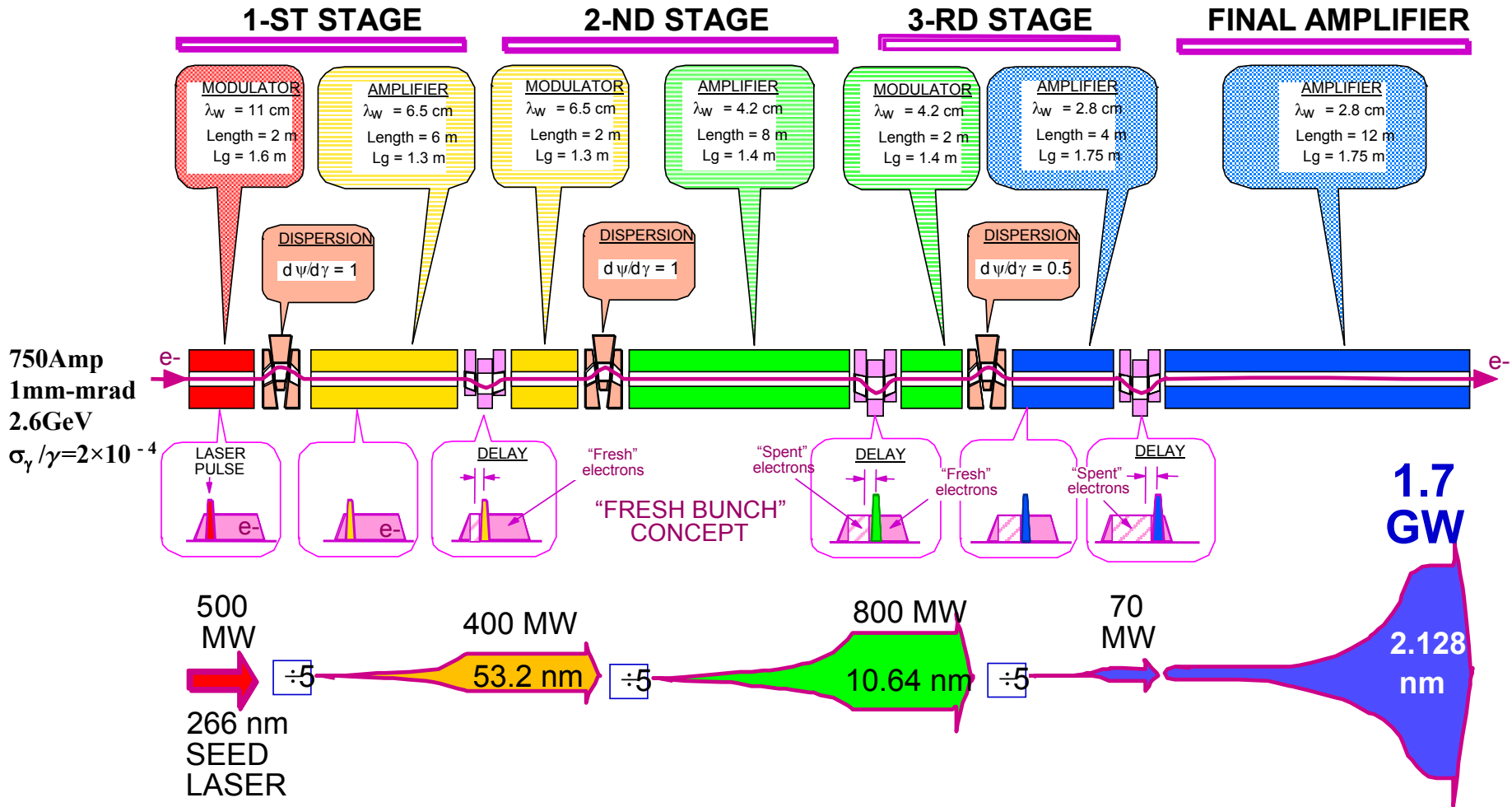

- Timing between e-bunch and laser < 100 fs (feedback)
- Noise degradation may be an issue to reach hard x-ray

# Two-stage FEL (DESY)

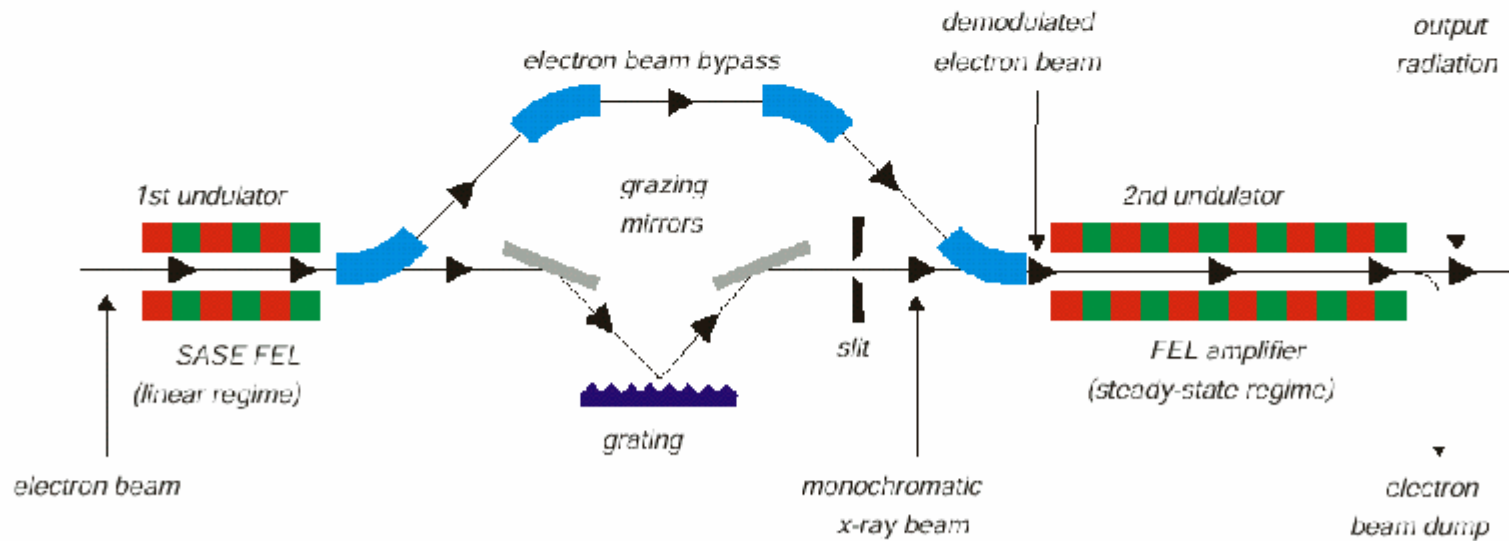
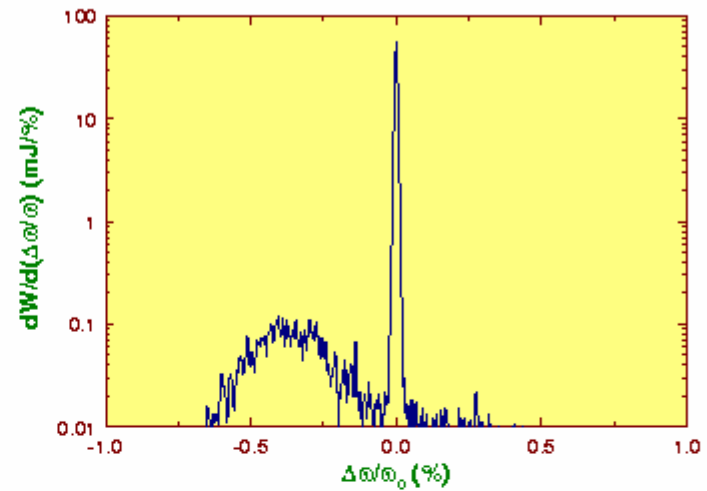
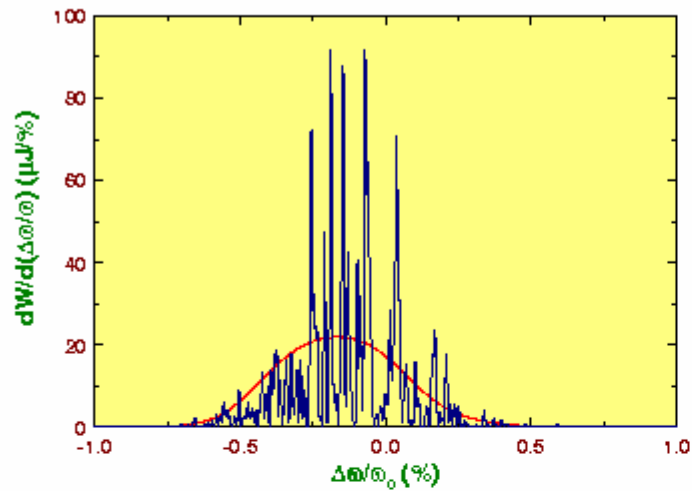

## 2-stage vs. SASE+Monochromator

- Both gives the desired bandwidth  $\sigma_m$  (of the monochromator)
- Advantage of 2-stage
  - spectral brightness increase by  $\sigma_\omega/\sigma_m$
  - reduced intensity fluctuation  
(if single mode selected, SASE fluctuates 100%, but 2-stage ~10% after saturation)
  - reduced radiation damage to optics
- 2-stage funded for TTFII
- any limitation to go to hard x-ray wavelengths ?

# The Regenerative FEL

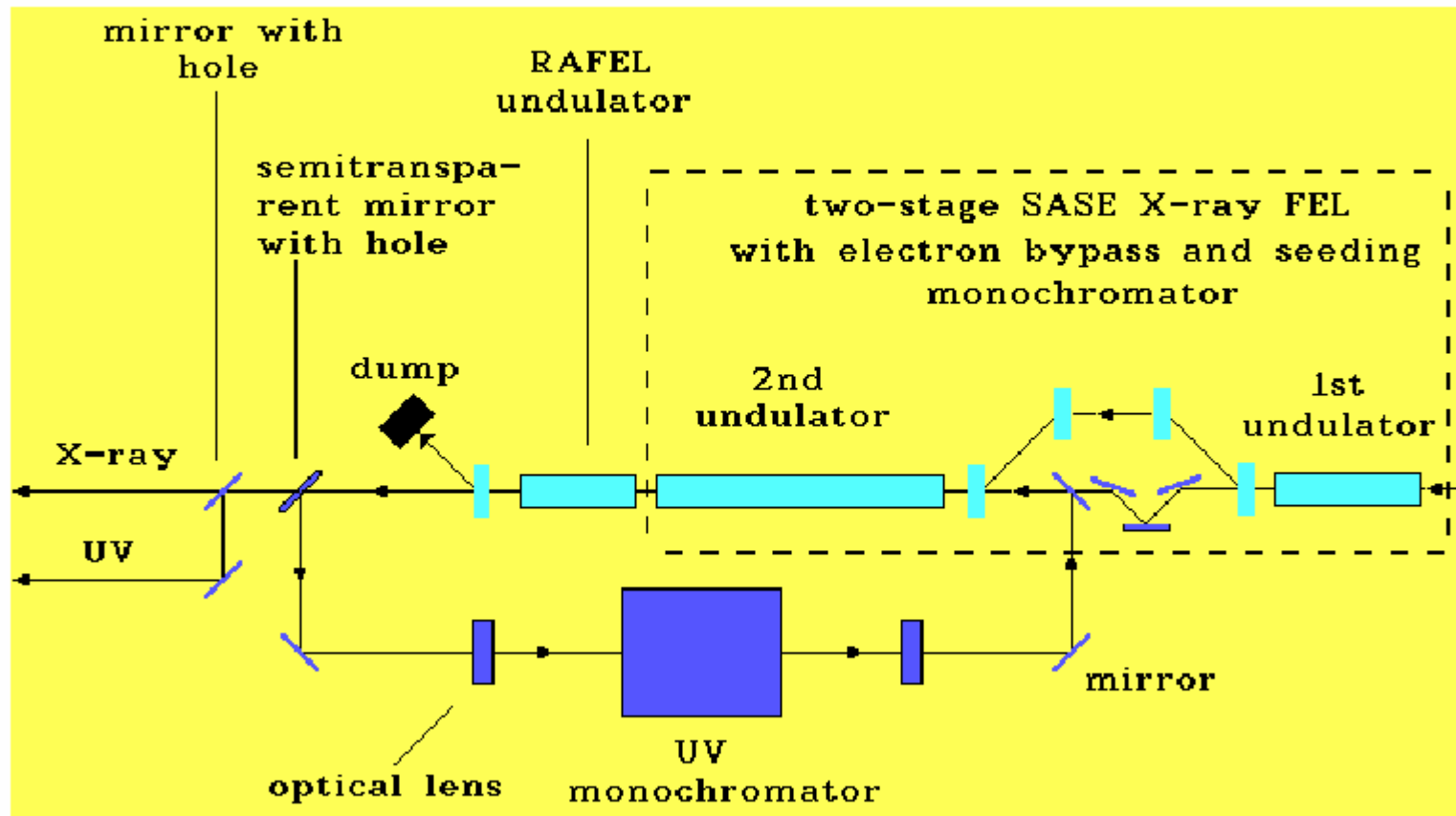

- RAFEL has been tested at TTF and did not work so far
- In x-ray wavelengths, some perfect crystals can have ~100% reflectivity in backscattering geometry

# X-ray Pulse Compression

- works the same as the electron bunch compression

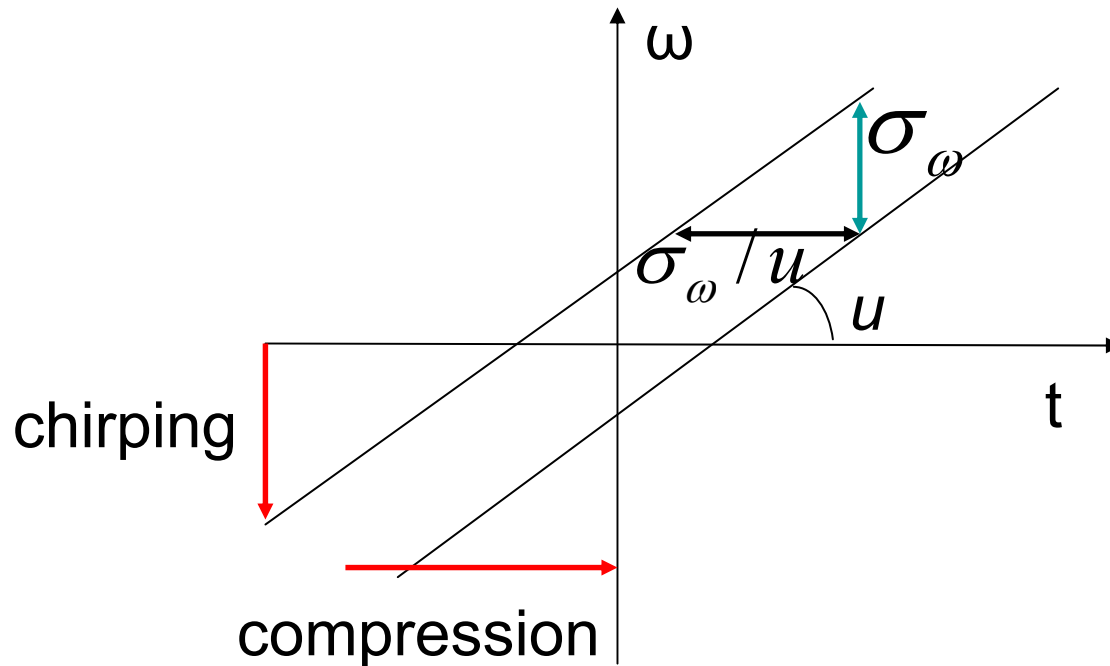

- No CSR, but demanding x-ray optics (a grating pair)
- Compressed pulse length limited by  $\sigma_\omega / u \sim 10$  fs

# X-ray Pulse Slicing

- frequency-chirped SASE + monochromator
- Pulse length minimum  $\sigma_\omega / u$ , but loses power
- Broad minimum  $\rightarrow$  control  $M_F$  (and fluctuation) through monochromator bandwidth

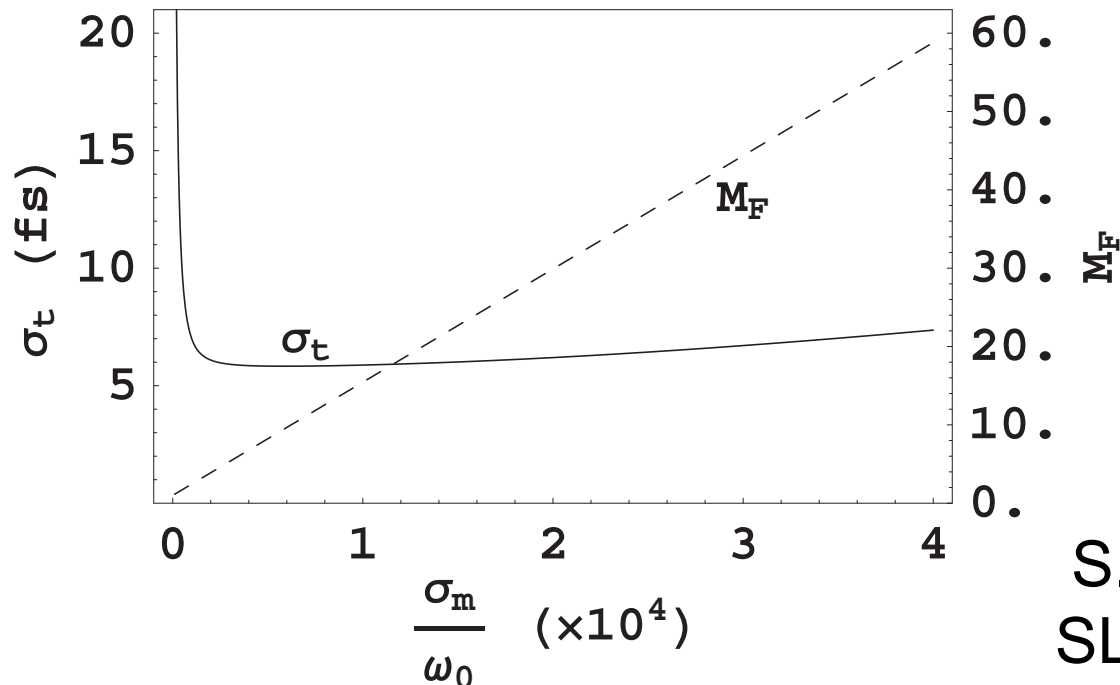

S. Krinsky & Z. Huang  
SLAC-PUB-9633, 2003

C. Schroeder et al.

## Two-stage Pulse Slicing

- Slicing before saturation reduces power load on monochromator
- Second stage seeded with sliced pulse (microbunching removed by bypass)
- Allows small bandwidth for unchirped bunches

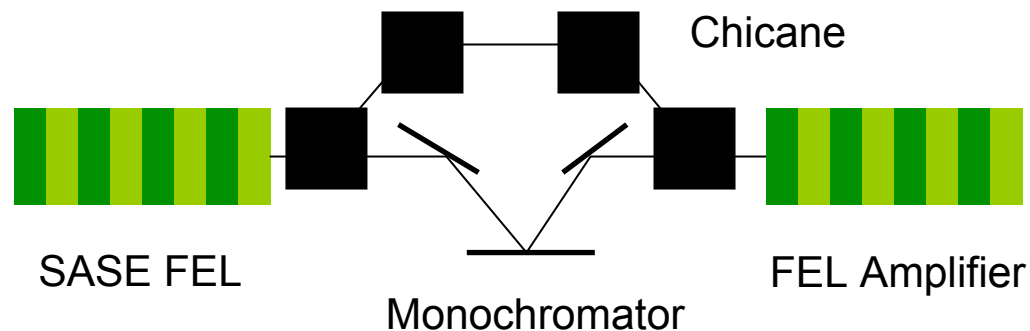

- Larger FEL bandwidth than at saturation when slicing, potentially longer x-ray pulse length than 1-stage
- Synchronization between sliced pulse and the part of electrons having the “right” energy

S. Reiche

# Wakefield Effects

Ideal case (step profile) with various materials for the vacuum chamber to control wakefield amplitude

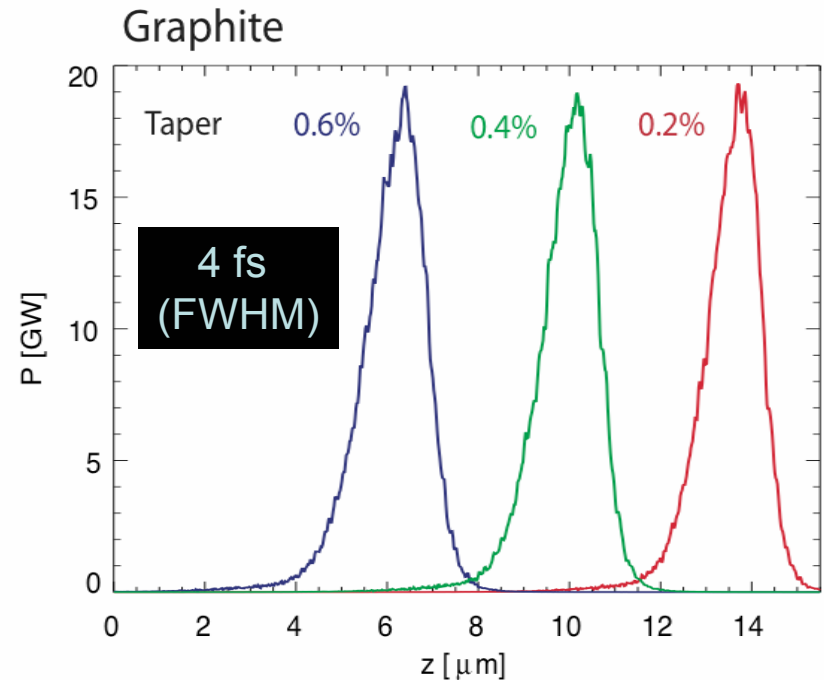
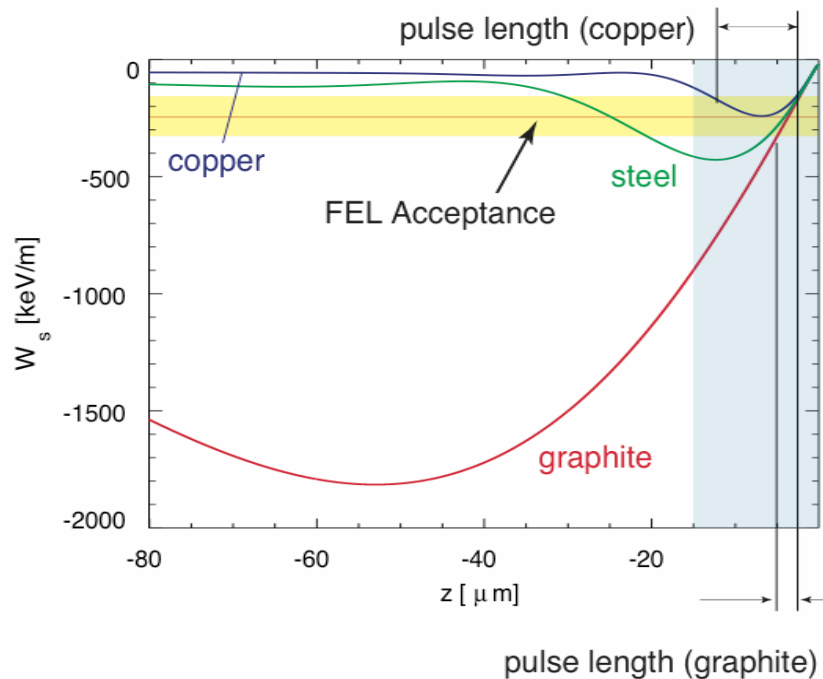

# Spatially Chirped Bunch

- FEL gain is very sensitivity to the offset of the slice centroid
- Mean Power vs. Initial  $y$ -centroid  $e^-$  Offset

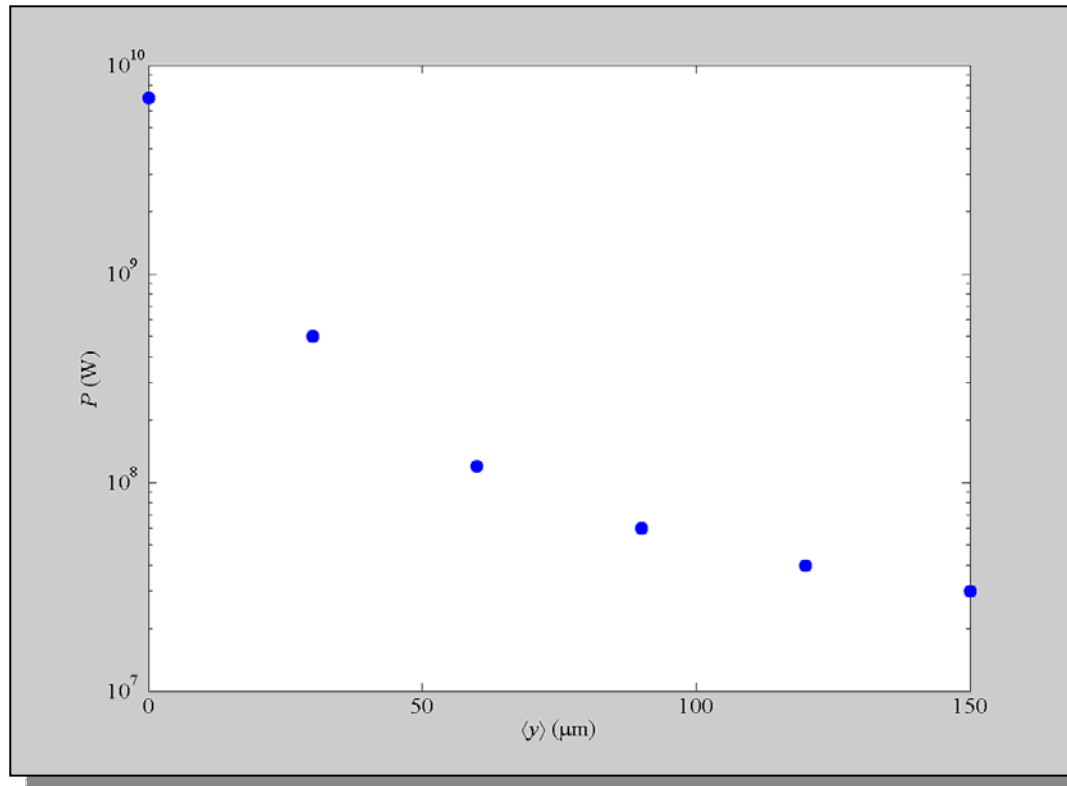

- A spatially-chirped bunch will lase mainly in the part that's initially on the undulator axis

# TCAV prior to BC2 @ $V_{\text{cav}} = 5 \text{ MV}$ , $L_{\text{cav}} = 1.0 \text{ m}$ , $E_{\text{cav}} = 4 \text{ GeV}$

$y$  vs.  $z$  at start of undulator

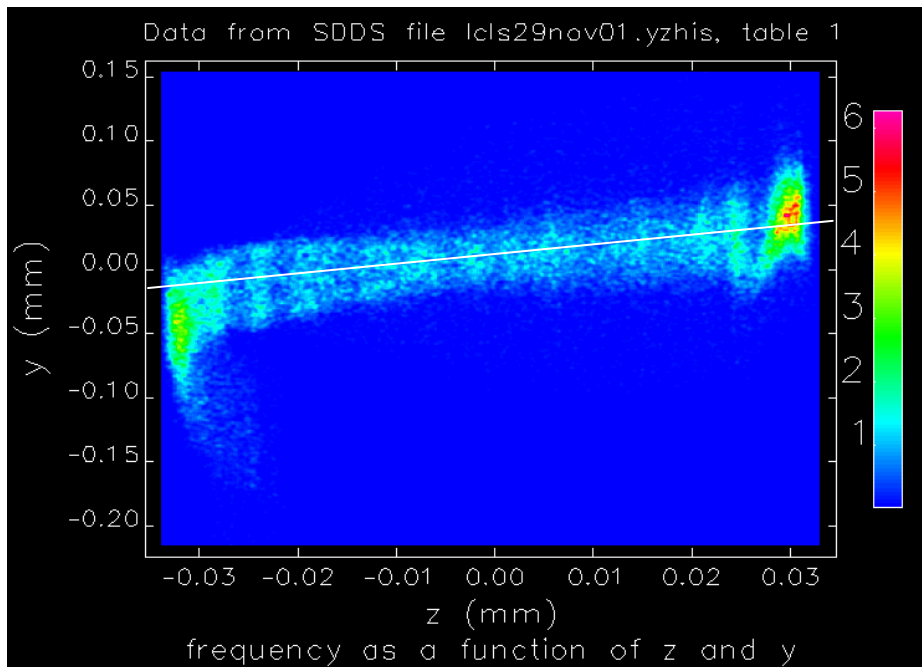

$y'$  vs.  $z$  at start of undulator

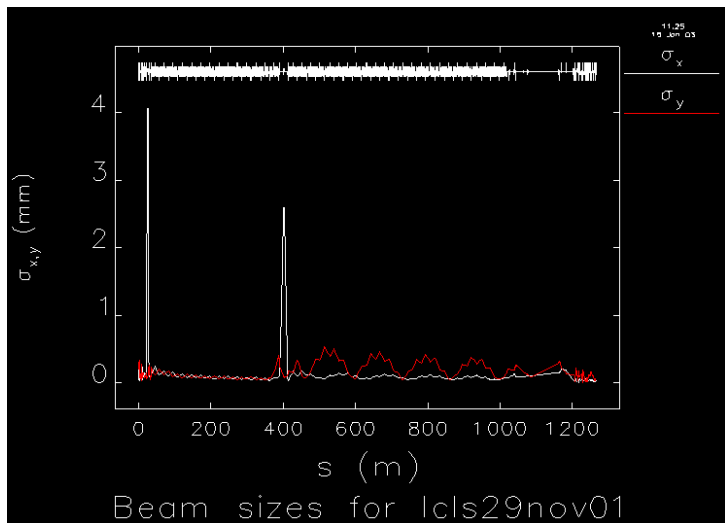
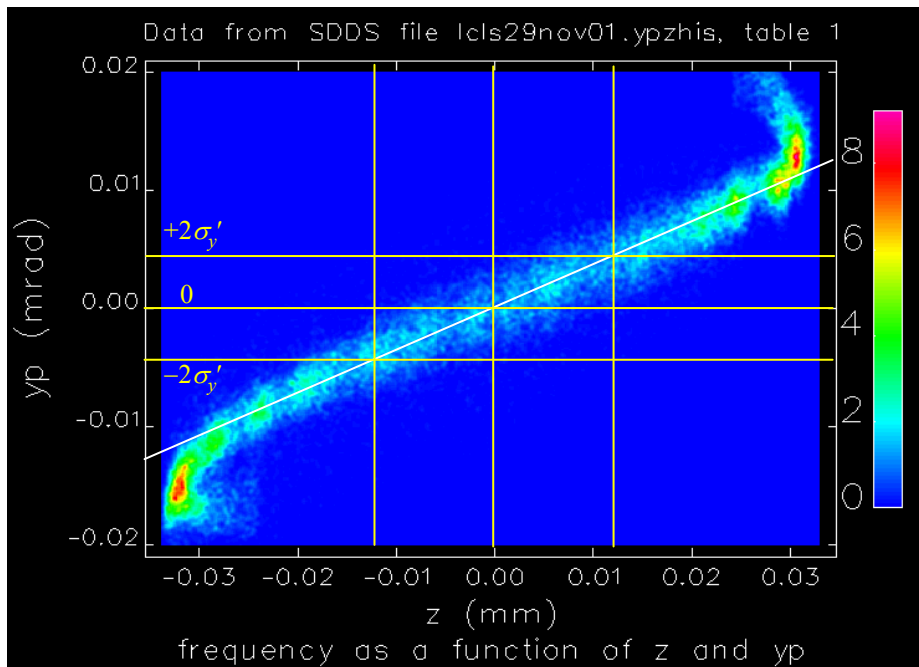

P. Emma

slope = 0.36 mrad/mm

$\sigma_y'(V=0) = 0.002 \text{ mrad}$

<2% FEL power at  $\pm 10 \mu\text{m}$

FWHM x-ray pulse  $\sim 20 \text{ fs}$

$\Delta\phi_{\text{rms}} < 0.5 \text{ deg S-band}$

# Sideband Seeded Soft XFEL

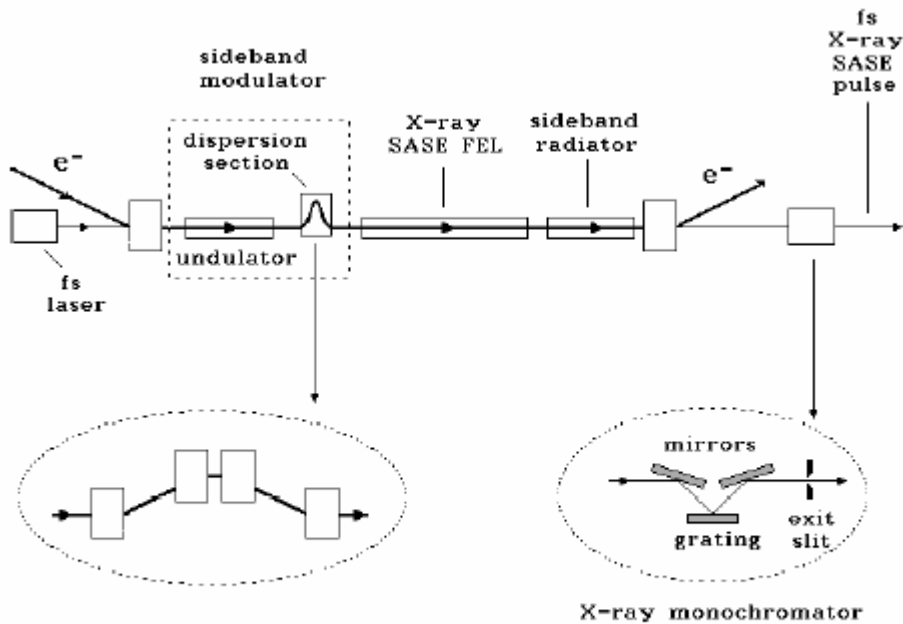

density modulation has the form

$$A_0 [1 + M \cos(\omega_{opt}t + c)] \cos(\omega_0 t + d)$$

$e^-$  bunch  
at the exit  
of SASE FEL

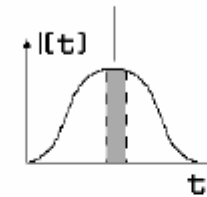

$$M/A_0 = 0.2$$

$$A_0 M/2 = 0.1 A_0$$

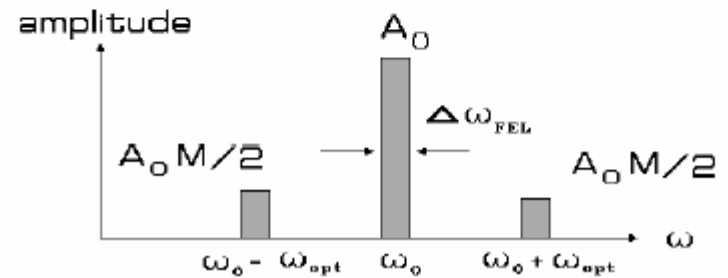
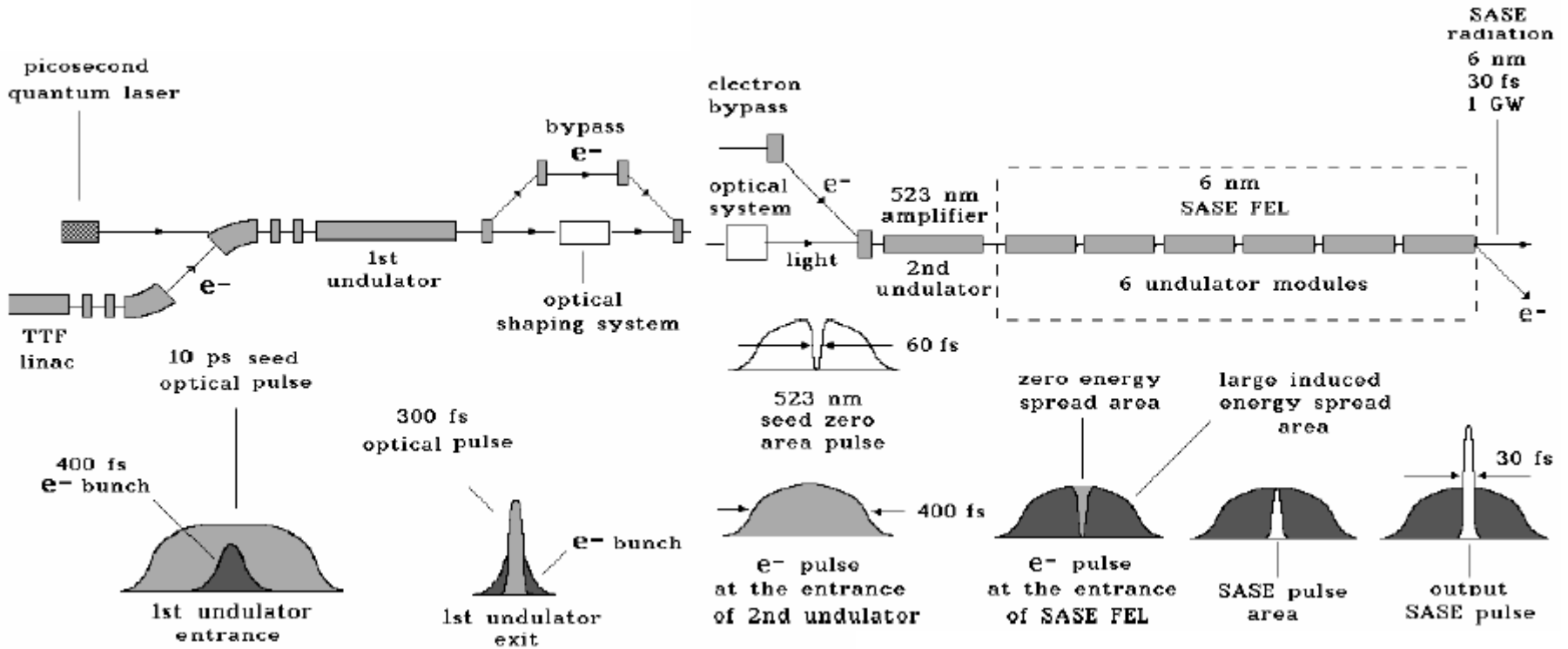

Fig. 1. Basic scheme of a sideband seeded SASE FEL

Need clear sideband separation  $\lambda_0/\lambda_L \gg \rho$ ,  
this limits shortest  $\lambda_0 \sim 10$  nm

# Laser Manipulation of energy spread



resolves the timing issue

shape laser and electron

short-pulse x-ray generation

# Statistical Single-Spike Selection

## Unseeded HGHG (E. Saldin)

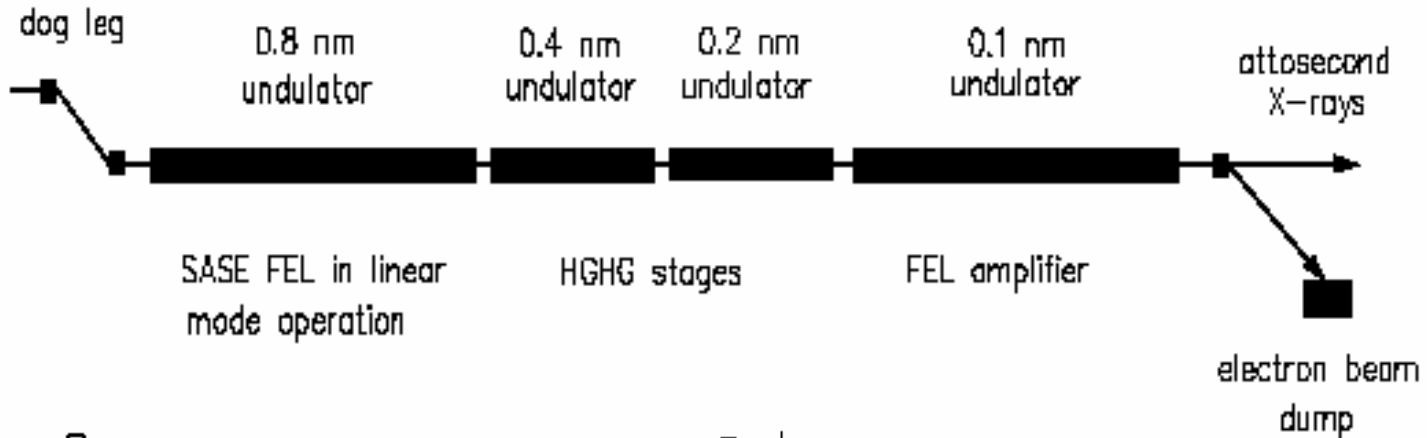

0.8 nm

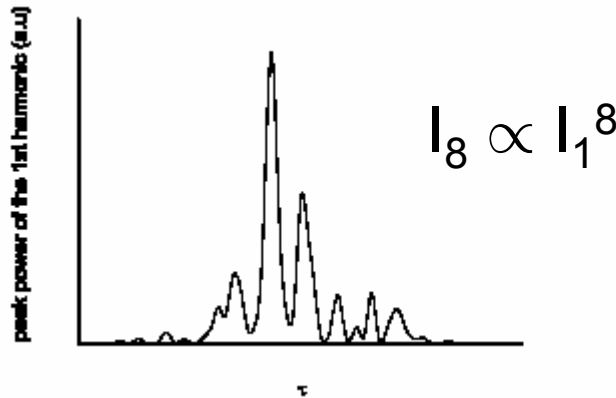

0.1 nm

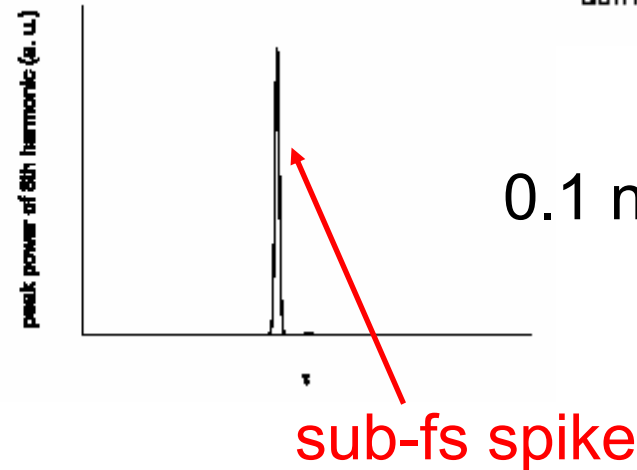

# Selection Process

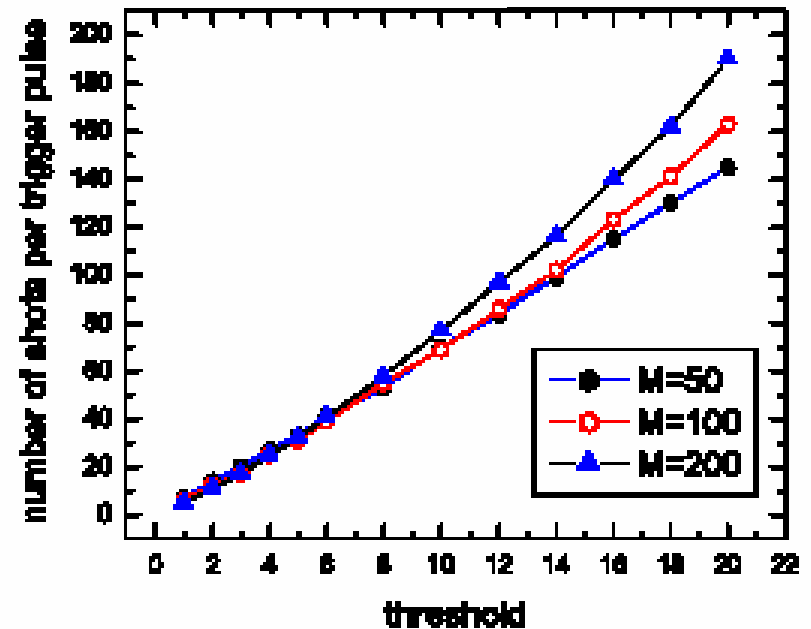
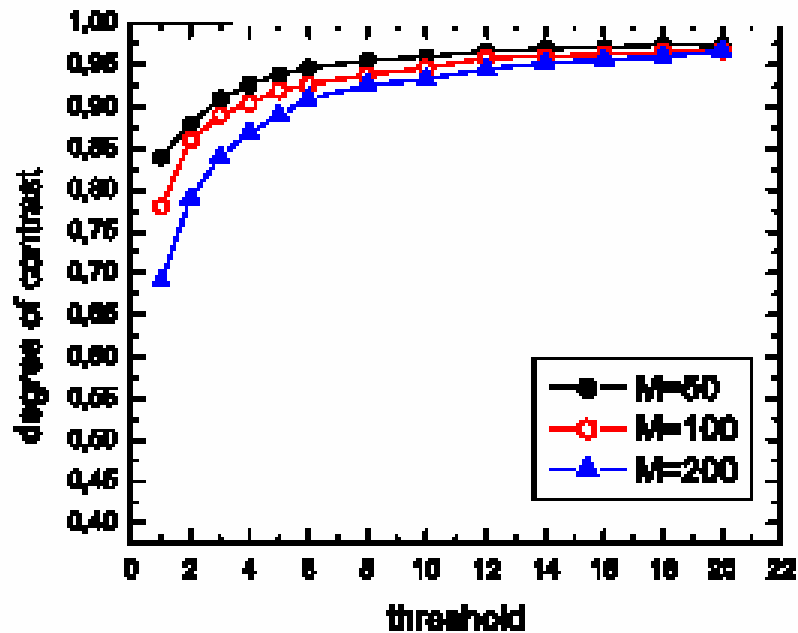
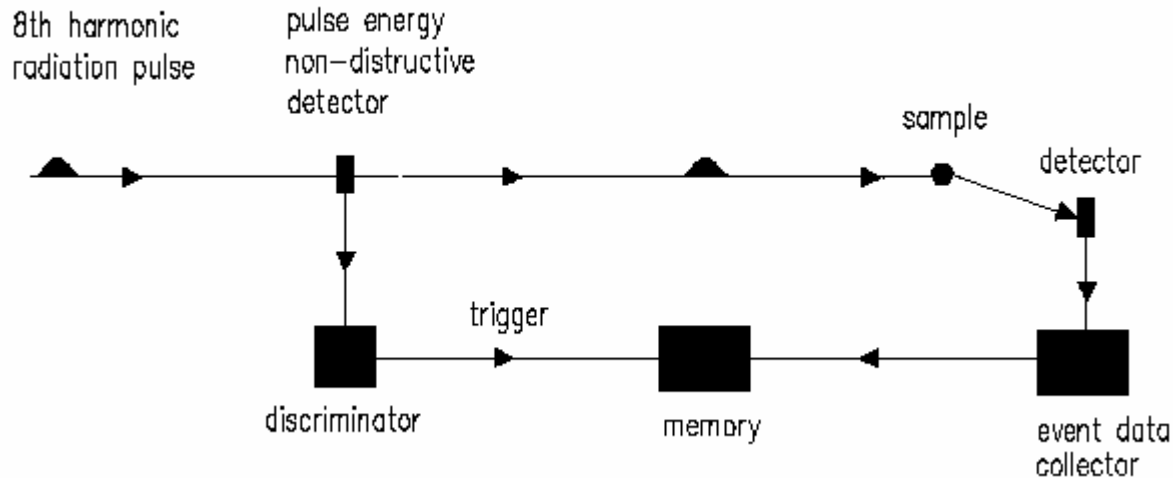

# Method

# Attosecond slicing (M. Zoloterov)

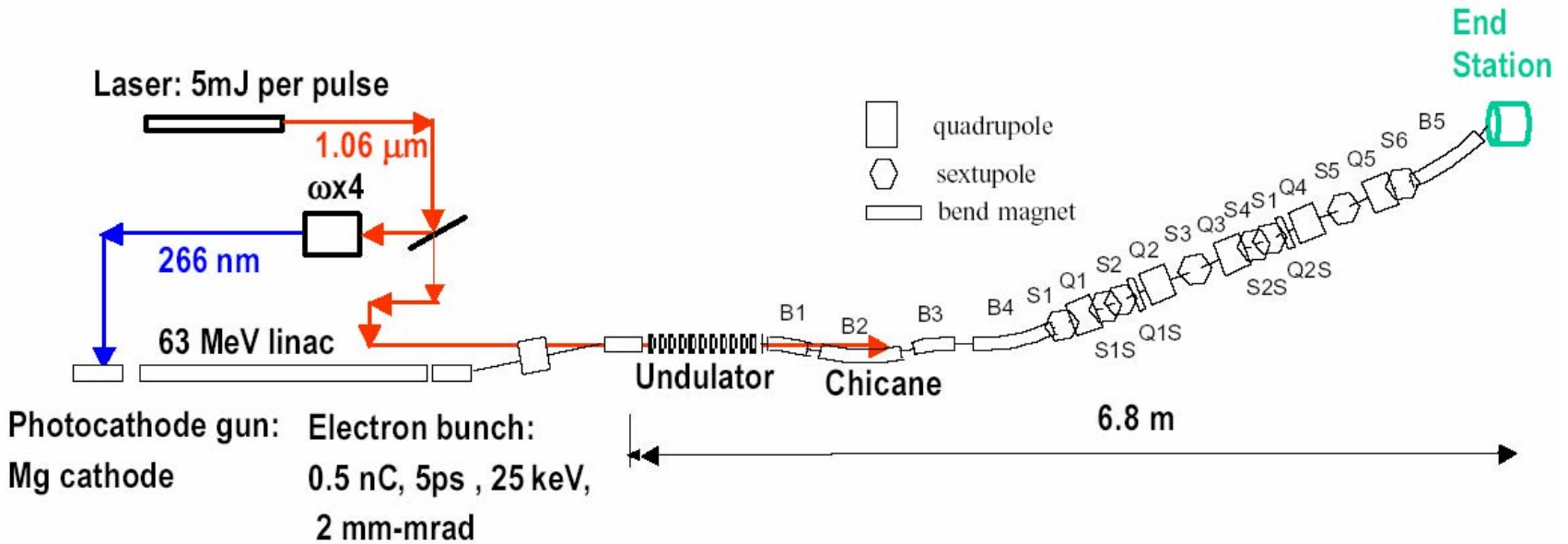

## e-beam-light interaction in the undulator

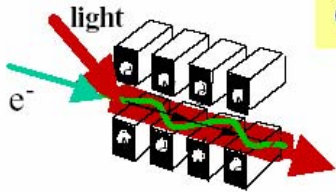

$$(\Delta\gamma)^2 = 32\pi M \frac{P}{P_0} \xi [J_0(\zeta/2) - J_1(\zeta/2)]^2$$

laser peak power  $P$   
Bessel functions  $J_0, J_1$   
undulator parameter  $\xi$   
number of undulator periods  $M$   
 $8.7 \times 10^9 \text{ W}$

$$\xi = \frac{K^2 / 2}{1 + K^2 / 2}$$

undulator parameter

# Method

cont'd

Estimate:  $\delta E = 0.6$  MeV for  $P = 10$  MW,  $K = 1.28$ ,  $M = 55$

Simulations (GINGER was used)

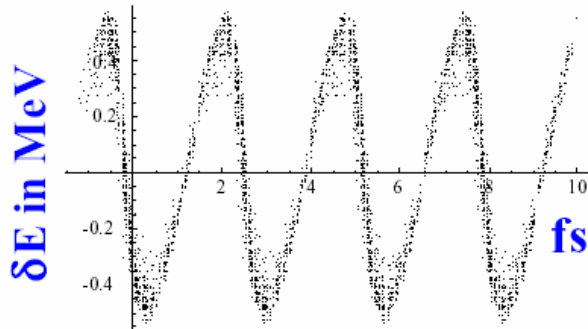

Longitudinal phase space at the exit of the undulator.

Modulation amplitude =  $40 \sigma_e$

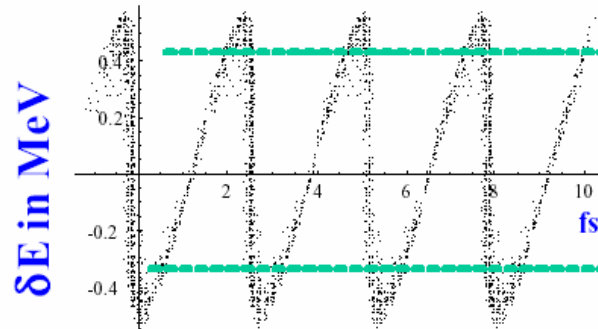

Longitudinal phase space at the End Station

Histogram of electron longitudinal density

